

# Physics

Single correct answer type:

1. A person observes that the full length of a train subtends an angle of  $15^\circ$ . If the distance between the train and the person is  $3km$ , the length of the train, calculated using parallax method, in meters is

- (A) 45
- (B)  $45\pi$
- (C)  $250\pi$
- (D)  $75\pi$
- (E) 450

Solution: (C)

Full length of the train subtends  $15^\circ$  angle

$$15^\circ = 15 \times \frac{\pi}{180} \text{ Radian}$$
$$= \frac{\pi}{12} \text{ Radian}$$

Given that, distance between train and person is  $3km$ .

i.e.,  $3km = 3000 \text{ meter}$

$$\text{Length of the train} = \text{Radius} \times \text{Angle} = 3000 \times \frac{\pi}{12}$$
$$= 250\pi$$

2. In a measurement, random error

- (A) Can be decreased by increasing the number of readings and averaging them
- (B) Can be decreased by changing the person who takes the reading
- (C) Can be decreased by using new instrument
- (D) Can be decreased by using a different method in taking the reading
- (E) Cannot be decreased

Solution: (A)

In a measurement, the random error can be minimized by increasing the number of readings and averaging them.

3. In order to measure the period of a single pendulum using a stop clock, a student repeated the experiment for 10 times and noted down the time period for each experiment as  $5.1, 5.0, 4.9, 5.1, 5.0, 4.9, 5.1, 5.0, 4.9$  s. The correct way of expressing the result for the period is

- (A)  $4.99 \text{ s}$
- (B)  $5.0 \text{ s}$
- (C)  $5.00 \text{ s}$
- (D)  $4.9 \text{ s}$
- (E)  $5.1 \text{ s}$

Solution: (B)

$$\text{Mean} = \frac{\sum x_i f_i}{10} = \frac{(4.9 \times 4) + (5.0 \times 3) + (5.1 \times 3)}{10} = 4.99 \text{ s}$$

Which can be round off to 5.0 s correct to two significant figures.

4. The following figure gives the movement of an object. Select the correct statement from the given choices.

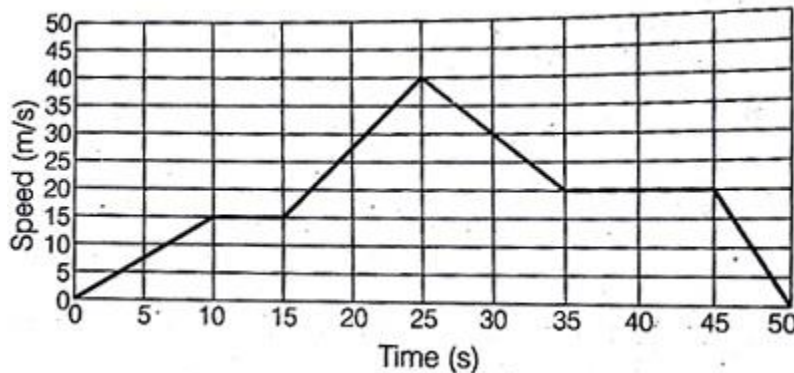

- (A) The total distance travelled by the object is 975m
- (B) The maximum acceleration of the object is  $2 \text{ m/s}^2$
- (C) The maximum deceleration happened between 25th and 35th seconds
- (D) The object was at rest between 10th and 15th seconds
- (E) At 40th second, the speed of object was decelerating

Solution: (A)

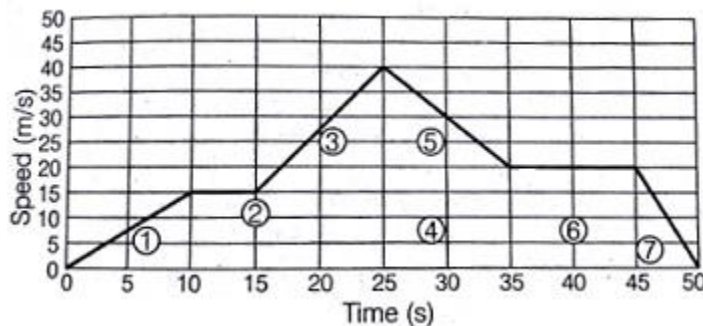

The total distance travelled by the object will be area of given graph in the figure.

So, the total distance travelled by the object = Area of (1) + Area of (2) + Area of (3) + Area of (4) + Area of (5) + Area of (6) + Area of (7)

$$\begin{aligned} &= \frac{1}{2} \times 10 \times 15 + (20 - 10) \times (15 - 0) + \frac{1}{2} (25 - 15) \times (40 - 15) + (35 - 25) \\ &\quad \times (20 - 0) + \frac{1}{2} (35 - 25) \times (40 - 20) + (45 - 35) \times (20 - 0) + \frac{1}{2} (50 - 45) \\ &\quad \times (15 - 0) \\ &= 975 \text{ m} \end{aligned}$$

5. Two object  $P$  and  $Q$ , travelling in the same direction starts from rest. While the object  $P$  starts at time  $t = 0$  and object  $Q$  starts later at  $t = 30 \text{ min}$ . The object  $P$  has an

acceleration of  $40 \text{ km/h}^2$ . To catch  $P$  at a distance of  $20 \text{ km}$ , the acceleration of  $Q$  should be

- (A)  $40 \text{ km/h}^2$
- (B)  $80 \text{ km/h}^2$
- (C)  $100 \text{ km/h}^2$
- (D)  $120 \text{ km/h}^2$
- (E)  $160 \text{ km/h}^2$

Solution: (E)

According to question,

Object  $P$  starts at  $t = 0$  and acceleration of  $P = 40 \text{ km/h}^2$

The time taken by object  $P$  to cover  $20 \text{ km}$  will be,

$$s = u + \frac{1}{2}at^2$$

Where,  $u = 0, s = \frac{1}{2}at^2$

$$t = \sqrt{\frac{2s}{a}}$$

Here,  $a = 40 \text{ km/h}^2$

and  $s = 20 \text{ km}$

$$t = \sqrt{\frac{2 \times 20}{40}}$$

$= 1 \text{ hour}$

Time taken by  $Q$  will be  $\frac{1}{2}$  hour, because he started after 30 min.

The acceleration in  $Q$ ,

$$a = \frac{2s}{t^2} = \frac{2 \times 20}{\left(\frac{1}{2}\right)^2}$$

$= 2 \times 4 \times 20$

$= 160 \text{ km/h}^2$

6. A train of length  $L$  move with a constant speed  $V_t$ . A person at the back of the train fires a bullet at time  $t = 0$  towards a target which is at a distance of  $D$  (at time  $t = 0$ ) from the front of the train (on the same direction of motion). Another person at the front of the train fires another bullet at time  $t = T$  towards the same target. Both bullets reach the target at the same time. Assuming the speed of the bullets  $V_b$  are same, the length of the train is

- (A)  $T \times (V_b \times 2V_t)$
- (B)  $T \times (V_b \times V_t)$
- (C)  $2 \times T \times (V_b + 2V_t)$
- (D)  $2 \times T \times (V_b - 2V_t)$
- (E)  $T \times (V_b - 2V_t)$

Solution: (B)

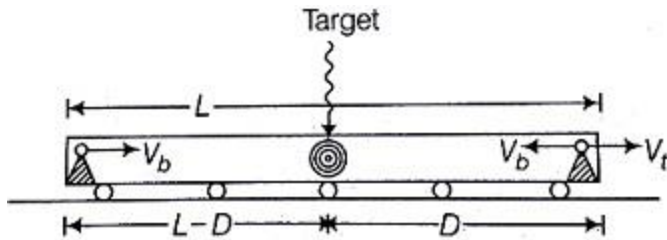

Bullets from both person reaches target at same instant, so we equate time to get,

$$\frac{L-D}{V_b - V_t} = \frac{D}{V_b - V_t} + T$$

$$\frac{L}{V_b - V_t} = \frac{D}{V_b + V_t} + \frac{D}{V_b - V_t} + T$$

$$= \frac{D(V_b - V_t + V_b + V_t)}{V_b^2 - V_t^2} + T$$

$$\frac{L}{V_b - V_t} = \frac{2V_b D}{V_b^2 - V_t^2} + T$$

$$\Rightarrow L = \frac{2V_b D}{V_b + V_t} + T(V_b - V_t)$$

7. From the ground, a projectile is fired at an angle of 60 degrees to the horizontal with a speed of 20 m/s. Take, acceleration due to gravity as 10 m/s<sup>2</sup>. The horizontal range of the projectile is

- (A) 10√3 m
- (B) 20 m
- (C) 20√3 m
- (D) 40√3 m
- (E) 400√3 m

Solution: (C)

The horizontal range

$$R = \frac{u^2 \sin 2\theta}{g}$$

Given,  $u = 20 \text{ m/s}$

$\theta = 60^\circ$

$g = 10 \text{ m/s}^2$

$$R = \frac{(20)^2 \sin(2 \times 60^\circ)}{10}$$

$$= \frac{20 \times 20}{10} \times \frac{\sqrt{3}}{2} = 20\sqrt{3} \text{ m}$$

8. A person from a truck, moving with a constant speed of 60 km/h, throws a ball upwards with a speed of 60 km/h. Neglecting the effect of Earth and choose the correct answer from the given choice.

- (A) The person cannot catch the ball when it comes down since the truck is moving

- (B) The person can catch the ball when it comes down, if the truck is stopped immediately after throwing the ball
- (C) The person can catch the ball when it comes down, if the truck moves with speed less than  $60 \text{ km/h}$  but does not stop
- (D) The person can catch the ball when it comes down, if the truck moves with speed more than  $60 \text{ km/h}$
- (E) The person can catch the ball when it comes down, if the truck continues to move with a constant speed of  $60 \text{ km/h}$ .

Solution: (E)

When the person throws a ball in upward direction from moving truck, ball also acquires a speed of  $60 \text{ km/h}$  in horizontal direction. So, if truck continues to move with same speed, ball comes down again in hands of person.

9. A body of mass  $2m$  moving with velocity  $v$  makes a head on elastic collision with another body of mass  $m$  which is initially at rest. Loss of kinetic energy of the colliding body (mass  $2m$ ) is

- (A)  $\frac{1}{9}$  of its initial kinetic energy
- (B)  $\frac{1}{6}$  of its initial kinetic energy
- (C)  $\frac{1}{4}$  of its initial kinetic energy
- (D)  $\frac{1}{2}$  of its initial kinetic energy
- (E)  $\frac{8}{9}$  of its initial kinetic energy

Solution: (E)

Initial  $K.E$  of ball of mass  $2m = K_1$

$$= \frac{1}{2} \times 2m \times v^2$$

$$= mv^2$$

Collision is elastic so both  $K.E$  and momentum are conserved. Let velocities of balls be  $v_1$  and  $v_2$  after collision.

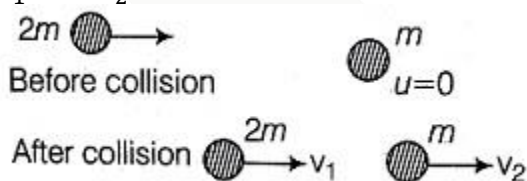

So,  $KE$  is conserved

$$\frac{1}{2}(2m)v^2 = \frac{1}{2}(2m)v_1^2 + \frac{1}{2}mv_2^2$$

$$\Rightarrow v^2 = v_1^2 + \frac{1}{2}v_2^2 \quad \dots (i)$$

And, momentum is conserved

$$(2m)v + m(0) = 2m(v_1) + mv_2$$

$$\Rightarrow 2v = 2v_1 + v_2 \quad \dots (ii)$$

Now,

$$v_2 = 2(v - v_1)$$

Put this value in Equation (i), we get

$$v^2 = v_1^2 + \frac{1}{2} \times 4(v - v_1)^2$$

$$\Rightarrow 3v_1^2 - 4vv_1 + v^2 = 0$$

$$\Rightarrow 3\left(\frac{v_1}{v}\right)^2 - 4\left(\frac{v_1}{v}\right) + 1 = 0$$

$$\text{or } \frac{v_1}{v} = \frac{-(-4) \pm \sqrt{16-12}}{2 \times 3}$$

$$\Rightarrow \frac{v_1}{v} = \frac{4 \pm 2}{2 \times 3}$$

$$\Rightarrow v_1 = v \text{ (Not possible)}$$

$$\text{or } v_1 = \frac{1}{3}v$$

So, final  $K.E$  of ball of mass  $2m$ ,

$$k_2 = \frac{1}{2}(2m)(v_1^2) = \frac{1}{2} \times 2m \times \frac{v^2}{9} = \frac{1}{9}(k_1)$$

Hence, loss of  $K.E.$  of  $1^{st}$  ball

$$= K_1 - \frac{1}{9}K_1 = \frac{8}{9}K_1$$

10. Displacement  $x$  (in meters), of body of mass  $1kg$  as a function of time  $t$ , on a horizontal smooth surface is given as  $x = 2t^2$ . Then work done in the first one second by the external force is

- (A)  $1J$
- (B)  $2J$
- (C)  $4J$
- (D)  $8J$
- (E)  $16J$

Solution: (D)

Given displacement is,

$$x = 2t^2$$

$$\Rightarrow v = \text{velocity} = \frac{dx}{dt} = 4t$$

$$v_{\text{initial}} = v(t = 0)$$

$$= 4 \times 0 = 0 \text{ m/s}$$

$$v_{\text{final}} = v(t = 1)$$

$$= 4 \times 1 = 4 \text{ m/s}$$

$\Delta K.E$  = change in  $K.E$  of body

$$= \frac{1}{2}m(v_{\text{final}}^2 - v_{\text{initial}}^2)$$

$$= \frac{1}{2} \times 1 \times (16 - 0) = 8J$$

By work-kinetic energy theorem, work done =  $\Delta K.E = 8J$

11. A massless spring of length  $l$  and spring constant  $k$  is placed vertically on a table. A ball of mass  $m$  is just kept on top of the spring. The maximum velocity of the ball is

- (A)  $g \sqrt{\frac{m}{k}}$
- (B)  $g \sqrt{\frac{2m}{k}}$
- (C)  $2g \sqrt{\frac{m}{k}}$
- (D)  $\frac{g}{2} \sqrt{\frac{m}{k}}$
- (E)  $g \sqrt{\frac{m}{2k}}$

Solution: (A)

If  $x$  –displacement of free end of spring, then

$$mg = kx$$

$$\text{or } x = \frac{mg}{k}$$

$$\text{Time period of oscillation, } T = 2\pi \sqrt{\frac{m}{k}}$$

$\Rightarrow \omega = \text{Angular frequency}$

$$= \frac{2\pi}{T} = \sqrt{\frac{k}{m}}$$

Maximum velocity of oscillating mass

$$= V_{\max} = A\omega$$

$$= \frac{mg}{k} \times \sqrt{\frac{k}{m}} = g \sqrt{\frac{m}{k}}$$

12. Under the action of a constant force, a particle is experiencing a constant acceleration. The power is

- (A) Zero
- (B) Positive constant
- (C) Negative constant
- (D) Increasing uniformly with time
- (E) Decreasing uniformly with time

Solution: (D)

Instantaneous power is  $P = F \cdot v = F at$

As force and acceleration are constant.

So, velocity of the particle must be keep on increasing

Hence, power is increasing uniformly with time.

i.e.  $P \propto t$ .

13. A copper wire with a cross-section area of  $2 \times 10^{-6} m^2$  has a free electron density equal to

$5 \times 10^{22}/cm^3$ . If this wire carries a current of  $16 A$ , the drift velocity of the electron is

- (A)  $1 m/s$
- (B)  $0.1 m/s$
- (C)  $0.01 m/s$
- (D)  $0.001 m/s$
- (E)  $0.0001 m/s$

Solution: (D)

Drift velocity,  $V_d = \frac{1}{neA}$

Given,  $n = 5 \times 10^{22}/cm^3$

$= 5 \times 10^{22} \times 10^6/cm^3$

$e = 1.6 \times 10^{-19} C$

$A = 2 \times 10^{-6} m^2$

$I = 16 A$

$$v_d = \frac{16}{5 \times 10^{28} \times 16 \times 10^{-19} \times 2 \times 10^{-6}}$$
$$= \frac{1}{10^3} = 0.001 m/s$$

14. The resistance of the tungsten wire in the light bulb, which is  $120/75 W$  and powered by a  $120 V$  direct current supply, is

- (A)  $0.37 \Omega$
- (B)  $1.2 \Omega$
- (C)  $2.66 \Omega$
- (D)  $192 \Omega$
- (E)  $9 \times 10^3 \Omega$

Solution: (D)

Power of bulb =  $75 W$

Supply voltage =  $120 V$

$$R = \frac{V^2}{P}$$

$$= \frac{(120)^2}{75}$$

$$= \frac{120 \times 120}{75} = 192 \Omega$$

15. The value of the current  $I_1, I_2$  and  $I_3$  flowing through the circuit given below is



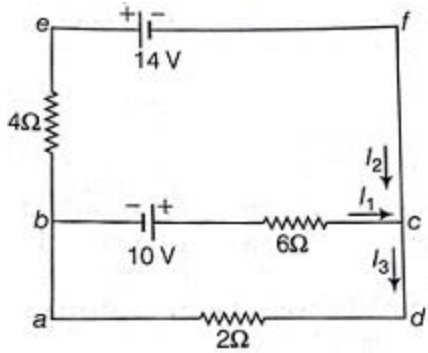

- (A)  $I_1 = -3A, I_2 = 2A, I_3 = -1A$
- (B)  $I_1 = 2A, I_2 = -3A, I_3 = -1A$
- (C)  $I_1 = 3A, I_2 = -1A, I_3 = -2A$
- (D)  $I_1 = 1A, I_2 = -3A, I_3 = -2A$
- (E)  $I_1 = 2A, I_2 = -1A, I_3 = -3A$

Solution: (B)

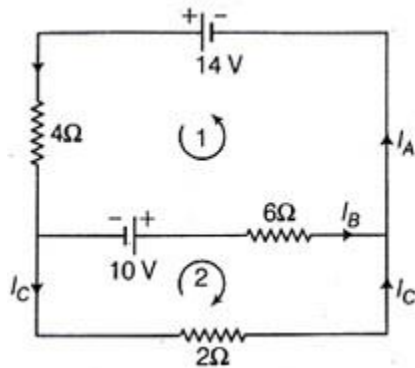

Applying Kirchoff's law

$$10 - 6I_B + 14 - 4I_A = 0 \quad \dots(\text{loop 1})$$

$$24 = 6I_B + 4I_A$$

$$12 = 3I_B + 2I_A \quad \dots(\text{i})$$

$$I_A = I_B + I_C \quad \dots(\text{junction})$$

$$10 - 6I_B + 2I_C = 0 \quad \dots(\text{loop 2})$$

$$10 = 6I_B - 2I_C$$

$$10 = 6I_B - 2(I_A - I_B) \quad \dots(\text{ii})$$

On solving Equations (i) and (ii), we get

$$I_B = 2A, I_A = 3A, I_C = 1A$$

Now as per given circuit,

$$I_1 = I_B = 2A, I_2 = -I_A = -3A$$

$$I_3 = -I_C = -1A$$

16. A silver wire has temperature coefficient of resistivity  $4 \times 10^{-3} / ^\circ C$  and its resistance at  $20^\circ C$  is  $10\Omega$ . Neglecting any change in dimensions due to the change in temperature, its resistance at  $40^\circ C$  is

- (A)  $0.8\Omega$
- (B)  $1.8\Omega$
- (C)  $9.2\Omega$

- (D)  $10.8\Omega$   
(E)  $11.6\Omega$

Solution: (D)

Given,  $\alpha = 4 \times 10^{-3} / ^\circ C$

$$T_1 = 20^\circ C$$

$$T_2 = 40^\circ C$$

$$Rt_2 = Rt_1(1 + \alpha\Delta t)$$

$$\Delta T = 40 - 0 = 20^\circ C$$

$$Rt_1 = 10\Omega$$

$$R_{40} = 10(1 + 4 \times 10^{-3} \times 20)\Omega$$

$$= 10[1 + 80 \times 10^{-3}]$$

$$= 10[1.08] = 10.8\Omega$$

17. A charge  $Q$  placed at the centre of a metallic spherical shell with inner and outer radii  $R_1$  and  $R_2$  respectively. The normal component of the electric field at any point on the Gaussian surface with radius between  $R_1$  and  $R_2$  will be

(A) Zero

(B)  $\frac{Q}{4\pi R_1^2}$

(C)  $\frac{Q}{4\pi R_2^2}$

(D)  $\frac{Q}{4\pi(R_1 - R_2)^2}$

(E)  $\frac{Q}{4\pi(R_2 - R_1)^2}$

Solution: (A)

The induced charges will appear at the inner and outer surface of the metallic spherical shell. Also there is no charge in between the metal of the shell. So, the normal component of the electric field at any point on the Gaussian surface with radius between  $R_1$  and  $R_2$  will be zero.

18. A sphere of radius  $R$  has a uniform volume charge density  $\rho$ . The magnitude of electric field at a distance  $r$  from the centre of the sphere, where  $r > R$ , is

(A)  $\frac{\rho}{4\pi\epsilon_0 r^2}$

(B)  $\frac{\rho R^2}{\epsilon_0 r^2}$

(C)  $\frac{\rho R^3}{\epsilon_0 r^2}$

(D)  $\frac{\rho R^3}{3\epsilon_0 r^2}$

(E)  $\frac{\rho R^2}{4\epsilon_0 r^2}$

Solution: (D)

$E (r > R)$

$$= \frac{\rho}{4\pi \epsilon_0 r^2}$$

$$= \frac{\rho R^3}{\left(\frac{4}{3}\pi R^3\right) 3\epsilon_0 r^2}$$

$$= \frac{\rho R^3}{3\epsilon_0 r^2}$$

19. Five equal point charges with  $Q = 10\text{nC}$  are located at  $x = 2, 4, 5, 10$  and  $20\text{m}$ . If  $\epsilon_0 = [10^{-9}/36\pi] \text{F/m}$ , then the potential at the origin ( $x = 0$ ) is

- (A) 9.9 V
- (B) 11.1 V
- (C) 90 V
- (D) 99 V
- (E) 111 V

Solution: (D)

Given  $Q = 10 \text{ nC} = 10 \times 10^{-9} \text{C}$

The potential point  $x = 0$ , will be the sum of potential produced by the charges placed at  $x = 2, 4, 5, 10$  and  $20$  meter.

Potential,  $V = \frac{k \cdot q}{r}$

Where,  $K = \frac{1}{4\pi\epsilon_0}$

$$V = \frac{q}{4\pi\epsilon_0 \times r}$$

Then,  $V_1 = \frac{q}{4\pi\epsilon_0 \times 2}$

$$V_2 = \frac{q}{4\pi\epsilon_0 \times 4}$$

$$V_3 = \frac{q}{4\pi\epsilon_0 \times 5}$$

$$V_4 = \frac{q}{4\pi\epsilon_0 \times 10}$$

$$V_5 = \frac{q}{4\pi \times 20}$$

The resultant potential,

$$V = V_1 + V_2 + V_3 + V_4 + V_5$$

$$= \frac{q}{4\pi\epsilon_0} \left[ \frac{1}{2} + \frac{1}{4} + \frac{1}{5} + \frac{1}{10} + \frac{1}{20} \right]$$

$$= \frac{1}{4\pi\epsilon_0} \left[ \frac{10 + 5 + 4 + 2 + 1}{20} \right]$$

$$= \frac{1}{4\pi\epsilon_0} \times \frac{10 \times 10^{-9} \times 22}{20}$$

$$= \frac{1 \times 36\pi}{4\pi \times 10^{-9}} \times \frac{10 \times 10^{-9} \times 22}{20}$$

$$= 99 \text{ V}$$

20. Two infinitely long parallel plates of equal areas  $6 \text{ cm}^2$  are separated by a distance of  $1 \text{ cm}$ . While one of the plates has a charge of  $+10 \text{ nC}$  and the other has  $-10 \text{ nC}$ . The magnitude of the electric field between the plates, if  $\epsilon_0 = \frac{10^{-9}}{36\pi} \text{ F/m}$  is

- (A)  $0.6 \pi \text{ V/m}$
- (B)  $6 \pi \text{ kV/m}$
- (C)  $600 \pi \text{ kV/m}$
- (D)  $60 \pi \text{ V/m}$
- (E)  $6 \pi$

Solution: (B)

We know that,

$$\begin{aligned}
 E &= \frac{q}{\epsilon_0 A} \\
 &= \frac{10^{-8} \times 36\pi}{10^{-9} \times 6 \times 10^{-4}} \text{ V/m} \\
 &= 6\pi \times 10^3 \\
 &= 6\pi \text{ kV/m}
 \end{aligned}$$

21. A proton moves with a speed of  $5.0 \times 10^6 \text{ m/s}$  along the  $x$ -axis. It enters a region where there is a magnetic field of magnitude  $2.0 \text{ Tesla}$  directed at an angle of  $30^\circ$  to the  $x$ -axis and lying in the  $xy$ -plane. The magnitude of the magnetic force on the proton is

- (A)  $0.8 \times 10^{-13} \text{ N}$
- (B)  $1.6 \times 10^{-13} \text{ N}$
- (C)  $8.0 \times 10^{-13} \text{ N}$
- (D)  $8.01 \times 10^{-13} \text{ N}$
- (E)  $16 \times 10^{-13} \text{ N}$

Solution: (C)

Given, The speed of proton,

$$v = 5.0 \times 10^6 \text{ m/s}$$

Magnetic field,  $B = 2.0 \text{ Tesla}$

Angle  $\theta = 30^\circ$

Charge on proton,  $q = 1.6 \times 10^{-19} \text{ C}$

When the proton enters in magnetic field, it experiences Lorentz force

$$F = q(v \times B)$$

$$|F| = qvB \sin \theta$$

$$F = 1.6 \times 10^{-19} \times 5 \times 10^6 \times 2 \times \sin 30^\circ$$

$$= 8.0 \times 10^{-13} \text{ N}$$

22. A long straight wire of radius  $R$  carries a steady current  $I_0$ , uniformly distributed throughout the cross-section of the wire. The magnetic field at a radial distance  $r$  from the centre of the wire, in the region  $r > R$ , is

- (A)  $\frac{\mu_0 I_0}{2\pi r}$

- (B)  $\frac{\mu_0 I_0}{2\pi R}$   
 (C)  $\frac{\mu_0 I_0 R^2}{2\pi r}$   
 (D)  $\frac{\mu_0 I_0 r^2}{2\pi R}$   
 (E)  $\frac{\mu_0 I_0 r^2}{2\pi R^2}$

Solution: (A)

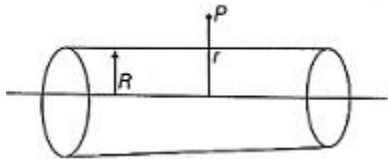

Radius of wire =  $R$

Steady current passing through the wire =  $I_0$

The magnetic field at radial distance  $r$  from the centre of the wire

$$\oint B \cdot dl = \mu_0 i$$

$$\Rightarrow B \int dl = \mu_0 I_0$$

$$\Rightarrow B = \frac{\mu_0 I_0}{2\pi r}$$

23. If the cyclotron oscillator frequency is  $16 \text{ MHz}$ , then what should be the operating magnetic field for accelerating the proton of mass  $1.67 \times 10^{-27} \text{ kg}$ ?

- (A)  $0.334 \pi \text{ T}$   
 (B)  $3.34 \pi \text{ T}$   
 (C)  $33.4 \pi \text{ T}$   
 (D)  $334 \pi \text{ T}$   
 (E)  $3340 \pi \text{ T}$

Solution: (A)

Given,

Frequency of cyclotron oscillator =  $16 \text{ MHz}$

$$\nu = 16 \times 10^6 \text{ Hz}$$

Mass of proton,  $m_p = 1.67 \times 10^{-27}$

The cyclotron frequency,

$$\nu = \frac{Bq}{2\pi m}$$

Where  $B$  = Required magnetic field

$$B = \frac{\nu \times 2\pi m}{q}$$

$$= \frac{16 \times 10^6 \times 2 \times \pi \times 1.67 \times 10^{-27}}{16 \times 10^{-19}} = 0.334 \pi \text{ T}$$

24. The speed of light in vacuum is equal to

- (A)  $\mu_0 \epsilon_0$
- (B)  $\mu_0^2 \epsilon_0^2$
- (C)  $\sqrt{\mu_0 \epsilon_0}$
- (D)  $\frac{1}{\mu_0 \epsilon_0}$
- (E)  $\frac{1}{\sqrt{\mu_0 \epsilon_0}}$

Solution: (E)

The speed of light in the vacuum is given by the formula

$$c = \frac{1}{\sqrt{\mu_0 \epsilon_0}}$$

Where,  $\mu_0$  = permeability of vacuum or air  
 $\epsilon_0$  = permittivity of air.

25. A comet orbits around the Sun in an elliptical orbit. Which of the following quantities remains constant during the course of its motion?

- (A) Linear velocity
- (B) Angular velocity
- (C) Angular momentum
- (D) Kinetic energy
- (E) Potential energy

Solution: (C)

When comet orbits around Sun in an elliptical orbit, it is under action of a central force and its angular momentum remains constant.

26. Consider a satellite moving in a circular orbit around Earth. If  $K$  and  $V$  denote its kinetic energy and potential energy respectively, then (Choose the convention, where  $V = 0$  as  $r \rightarrow \infty$ )

- (A)  $K = V$
- (B)  $K = 2V$
- (C)  $V = 2K$
- (D)  $K = -2V$
- (E)  $V = -2K$

Solution: (E) When a satellite moves in a circular orbit around the earth its

(i) Potential energy,

$$\therefore V = -\frac{GMm}{r}$$

(ii) Kinetic energy,

$$K = \frac{1}{2}mv^2 = \frac{GMm}{2r} \left[ \because v = \sqrt{\frac{GM}{r}} \right]$$

$$\therefore V = -2K$$

27. Assuming the mass of Earth to be ten times the mass of Mars, its radius to be twice the radius of Mars and the acceleration due to gravity on the surface of Earth is  $10 \text{ m/s}^2$ . Then the acceleration due to gravity on the surface of Mars is given by

- (A)  $0.2 \text{ m/s}^2$
- (B)  $0.4 \text{ m/s}^2$
- (C)  $2 \text{ m/s}^2$
- (D)  $4 \text{ m/s}^2$
- (E)  $5 \text{ m/s}^2$

Solution: (D)

Given, mass of earth =  $10 \times M_m$

Where,  $M_m$  = Mass of mars

Radius of earth =  $2 R_m$

Where,  $R_m$  = radius of mass

And  $g = \frac{GM}{R^2}$

Let gravity on the surface of mass is  $g_m$

$$\therefore \frac{g_m}{g_E} = \frac{M_m}{M_E} \times \left(\frac{R_E}{R_m}\right)^2$$

$$g_m = g_e \times \frac{M_m}{M_E} \left(\frac{R_E}{R_m}\right)^2$$

$$= 10 \times \frac{M_m}{10M_m} \left(\frac{2R_m}{R_m}\right)^2 = 4 \text{ m/s}^2$$

28. The semi-major axis of the orbit of Saturn is approximately nine times that of Earth. The time period of revolution of Saturn is approximately equal to

- (A) 81 years
- (B) 27 years
- (C) 729 years
- (D)  $\sqrt[3]{81}$  years
- (E) 9 years

Solution: (B)

Given, Semi-major axis of the orbit of Saturn =  $9 r_E$

Where,  $r_E$  = semi major axis of earth

According to Kepler's law,

$$T^2 \propto r^3$$

Let the time period of revolution of Saturn around the sun is  $T_S$

$$\therefore \frac{T_S^2}{T_E^2} = \left(\frac{9r_E}{r_E}\right)^3$$

$$T_S^2 = T_E^2(9)^3$$

$$T_S = \sqrt{T_E^2(9)^3}$$

$$= 9^{\frac{3}{2}} \times 1 \text{ year}$$

$\approx 27$  years

29. A particle of mass  $3\text{ kg}$ , attached to a spring with force constant  $48\text{ N/m}$  execute simple harmonic motion on a frictionless horizontal surface. The time period of oscillation of the particle, in seconds, is

- (A)  $\frac{\pi}{4}$
- (B)  $\frac{\pi}{2}$
- (C)  $2\pi$
- (D)  $8\pi$
- (E)  $\frac{\pi}{8}$

Solution: (B)

The time period of mass,

$$T = 2\pi \sqrt{\frac{m}{k}}$$

Given,  $m = 3\text{ kg}$

$k = 48\text{ N/m}$

$$T = 2\pi \sqrt{\frac{3}{48}} = 2\pi \sqrt{\frac{1}{16}}$$

$$= 2\pi \times \frac{1}{4} = \frac{\pi}{2}$$

30. The position and velocity of a particle executing simple harmonic motion at  $t = 0$  are given by  $3\text{ cm/s}$  and  $8\text{ cm/s}$  respectively. If the angular frequency of the particle is  $2\text{ rad/s}$ , then the amplitude of oscillation, in centimeters, is

- (A) 3
- (B) 4
- (C) 5
- (D) 6
- (E) 8

Solution: (C)

Given, the position and velocity of the particle executing *SHM*.

$$y = 3\text{ cm}$$

$$v = 8\text{ cm/s}$$

Angular frequency,  $\omega = 2\text{ rad/s}$

The velocity,

$$v = \omega \sqrt{a^2 - y^2}$$

$$8 = 2 \sqrt{a^2 - (3)^2}$$

$$4 = \sqrt{a^2 - (3)^2}$$

$$16 = a^2 - 9$$

$$a^2 = 25$$

$$a = 5\text{ cm}$$



31. A simple harmonic motion is represented by  $x(t) = \sin^2 \omega t - 2 \cos^2 \omega t$ . The angular frequency of oscillation is given by

- (A)  $\omega$
- (B)  $2\omega$
- (C)  $4\omega$
- (D)  $\frac{\omega}{2}$
- (E)  $\frac{\omega}{4}$

Solution: (B)  $x = \sin^2 \omega t - 2 \cos^2 \omega t$   
 $= 1 - 3 \cos^2 \omega t$   
 $= 1 - 3 \left( \frac{1 + \cos 2\omega t}{2} \right)$   
 $= -\frac{1}{2} - \frac{3}{2} \cos 2\omega t$

Which is a periodic function with angular frequency of  $2\omega$ .

32. A transverse wave is propagating on a stretched string of mass per unit length  $32 \text{ g/m}$ . The tension on the string is  $80 \text{ N}$ . The speed of the wave over the string is

- (A)  $\frac{5}{2} \text{ m/s}$
- (B)  $\sqrt{\frac{5}{2}} \text{ m/s}$
- (C)  $\frac{2}{5} \text{ m/s}$
- (D)  $\sqrt{\frac{2}{5}} \text{ m/s}$
- (E)  $50 \text{ m/s}$

Solution: (E)

Speed of wave in a string,

$$v = \sqrt{\frac{T}{\mu}}$$

Given,  $T = 80 \text{ N}$

$$\mu = 32 \text{ g/m}$$

$$= 32 \times 10^{-3} \text{ kg/m}$$

$$v = \sqrt{\frac{80}{32 \times 10^{-3}}} = \sqrt{\frac{8 \times 10^4}{32}}$$

$$= 100 \times \frac{1}{2}$$

$$= 50 \text{ m/s}$$

33. Consider the propagating sound (with velocity  $330\text{ m/s}$ ) in a pipe of length  $1.5\text{ m}$  with one end closed and the other open. The frequency associated with the fundamental mode is

- (A)  $11\text{ Hz}$
- (B)  $55\text{ Hz}$
- (C)  $110\text{ Hz}$
- (D)  $165\text{ Hz}$
- (E)  $275\text{ Hz}$

Solution: (B)

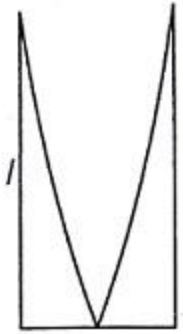

Given,

Velocity of sound =  $330\text{ m/s}$

Length of closed pipe =  $15\text{ m}$

In a closed pipe for fundamental mode

$$\frac{\lambda}{4} = l$$

$$\lambda = 4 \times 15 = 6\text{ m}$$

$$v = n\lambda$$

$$n = \frac{v}{\lambda}$$

$$= \frac{330}{6}$$

$$= 55\text{ Hz}$$

34. A standing wave propagating with velocity  $300\text{ m/s}$  in an open pipe of length  $4\text{ m}$  has four nodes. The frequency of the wave is

- (A)  $75\text{ Hz}$
- (B)  $100\text{ Hz}$
- (C)  $150\text{ Hz}$
- (D)  $300\text{ Hz}$
- (E)  $600\text{ Hz}$

Solution: (C)

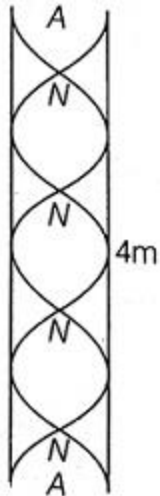

Nodes are produced in the open pipe as shown in figure.

$$\text{So, } 2\lambda = 4$$

$$\lambda = \frac{4}{2} = 2m$$

From wave equation,

$$v = n\lambda$$

$$n = \frac{v}{\lambda}$$

$$= \frac{300}{2}$$

$$= 150 \text{ Hz}$$

35. Consider the vehicle emitting sound wave of frequency  $700 \text{ Hz}$  moving towards an observer at a speed  $22 \text{ m/s}$ . Assuming the observer as well as the medium to be at rest and velocity of sound in the medium to be  $330 \text{ m/s}$ , the frequency of sound as measured by the observer is

(A)  $\frac{2525}{4} \text{ Hz}$

(B)  $\frac{1960}{3} \text{ Hz}$

(C)  $\frac{2240}{3} \text{ Hz}$

(D)  $750 \text{ Hz}$

(E)  $\frac{5625}{7} \text{ Hz}$

Solution: (D)

Given,

Speed of sound source =  $22 \text{ m/s}$

Frequency of emitted sound =  $700 \text{ Hz}$

Velocity of sound =  $330 \text{ m/s}$

When the sound source is moving the apparent frequency of sound heard by the observer

$$n' = n \left[ \frac{v}{v - v_s} \right]$$

$$\begin{aligned}
 n' &= 700 \left[ \frac{330}{300 - 22} \right] \\
 &= 700 \left[ \frac{330}{308} \right] \\
 &= 749.99 \\
 &\approx 750 \text{ Hz}
 \end{aligned}$$

36. The  $x - t$  plot shown in the figure below describes the motion of the particle, along  $x$ -axis, between two positions  $A$  and  $B$ . The particle passes through two intermediate points  $P_1$  and  $P_2$  as shown in the figure.

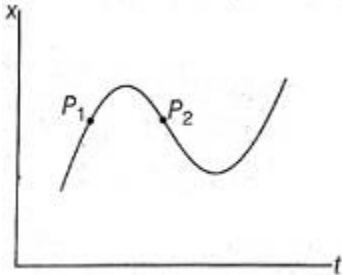

- (A) The instantaneous velocity is positive at  $P_1$  and negative at  $P_2$
- (B) The instantaneous velocity is negative at both  $P_1$  and  $P_2$
- (C) The instantaneous velocity is negative at  $P_1$  and positive at  $P_2$
- (D) The instantaneous velocity is positive at both  $P_1$  and  $P_2$
- (E) The instantaneous velocity is always positive

Solution: (A)

According to the figure, the displacement at point  $P_1$  is increasing, so velocity at  $P_1$  will be positive.

At point  $P_2$ , displacement is decreasing, so the instantaneous velocity will be negative.

37. A ball falls from a table top with initial horizontal speed  $V_0$ . In the absence of air resistance, which of the following statement is correct

- (A) The vertical component of the acceleration changes with time
- (B) The horizontal component of the velocity does not changes with time
- (C) The horizontal component to the acceleration is non zero and finite
- (D) The time taken by the ball to touch the ground depends on  $V_0$
- (E) The vertical component of the acceleration varies with time

Solution: (B)

When the ball falls from a table top with initial speed  $v_0$ , its horizontal component of the velocity will remain unchanged with time because there is no air resistance.

38. A man of mass  $60 \text{ kg}$  climbed down using an elevator. The elevator had an acceleration  $4 \text{ ms}^{-2}$ . If the acceleration due to gravity is  $10 \text{ ms}^{-2}$ , the man's apparent weight on his way down is

- (A)  $60 \text{ N}$
- (B)  $240 \text{ N}$

- (C) 360 N
- (D) 840 N
- (E) 3600 N

Solution: (C)

The man is climbing down using elevator, so the resultant gravity on the man will be

$$\begin{aligned} \therefore g' &= g - a = 10 - 4 \\ &= 6 \text{ m/s}^2 \end{aligned}$$

$$\begin{aligned} \text{The weight of the person, } W &= mg' \\ &= 60 \times 6 = 360 \text{ N} \end{aligned}$$

39. A uniform rod of length of 1 m and mass of 2 kg is attached to a side support at O as shown in the figure. The rod is at equilibrium due to upward force T acting at P. Assume the acceleration due to gravity as 10 m/s<sup>2</sup>. The value of T is

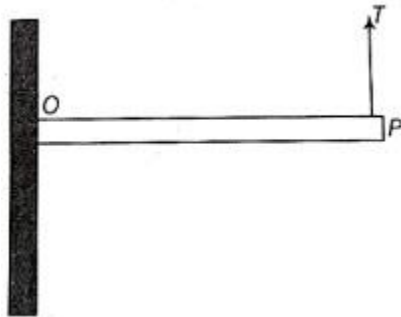

- (A) 0
- (B) 2 N
- (C) 5 N
- (D) 10 N
- (E) 20 N

Solution: (D)

The one end of the uniform rod is fixed and force T is acting in upward direction

So, at point P,

$$\begin{aligned} T &= \frac{mg}{2} \\ &= \frac{2 \times 10}{2} \\ &= 10 \text{ N} \end{aligned}$$

40. A capillary tube of radius 0.5 mm is immersed in a beaker of mercury. The level inside the tube is 0.8 cm below the level in beaker and angle of contact is 120°. What is the surface tension of mercury, if the mass density of mercury is  $\rho = 13.6 \times 10^3 \text{ kgm}^{-3}$  and acceleration due to gravity is  $g = 10 \text{ m/s}^2$ ?

- (A) 0.225 N/m
- (B) 0.544 N/m
- (C) 0.285 N/m
- (D) 0.375 N/m

(E)  $0.425 \text{ N/m}$

Solution: (B)

Given,

Radius of capillary tube =  $0.5 \text{ mm}$

$$= 0.5 \times 10^{-3} \text{ m}$$

Level inside tube =  $0.8 \text{ cm}$

$$= 0.8 \times 10^{-2} \text{ m}$$

Angle of contact,  $\theta = 120^\circ$

Mass density of mercury,

$$\rho = 13.6 \times 10^3 \text{ kg/m}^2$$

Acceleration due to gravity,  $g = 10 \text{ m/s}^2$

$$h = \frac{2T \cos \theta}{r \rho g}$$

$$T = \frac{hr \rho g}{2 \cos \theta}$$

$$= \frac{0.8 \times 10^{-2} \times 0.5 \times 10^{-3} \times 13.6 \times 10^3 \times 10}{2 \times \cos 120}$$

$$= \frac{0.8 \times 10^{-2} \times 0.5 \times 10^{-3} \times 13.6 \times 10^3 \times 10}{2 \times \frac{1}{2}}$$

$$= 0.8 \times 0.5 \times 13.6 \times 10^{-1}$$

$$= 0.544 \text{ N/m}$$

41. Which of the following statement related to stress-strain relation is correct?

- (A) Stress is linearly proportional to strain irrespective of the magnitude of the strain
- (B) Stress is linearly proportional to strain above
- (C) Stress is linearly proportional to strain for stress much smaller than at the yield point
- (D) Stress–strain curve is same for all materials
- (E) Stress is inversely proportional to strain

Solution: (C)

Stress is linearly proportional to strain for stress much smaller than at the yield point.

Because Hook's law gives (with in elastic limits).

Stress  $\propto$  Strain

42. The lower edge of a square slab of side  $50 \text{ cm}$  and thickness  $20 \text{ cm}$  is rigidly fixed to the base of a table. A tangential force of  $30 \text{ N}$  is applied to the slab. If the shear moduli of the material is  $4 \times 10^{10} \text{ N/m}^2$ , then displacement of the upper edge, in meters is

- (A)  $4 \times 10^{-12}$
- (B)  $4 \times 10^{-10}$
- (C)  $6 \times 10^{-10}$
- (D)  $6 \times 10^{-12}$
- (E)  $8 \times 10^{-10}$

Solution: (C)

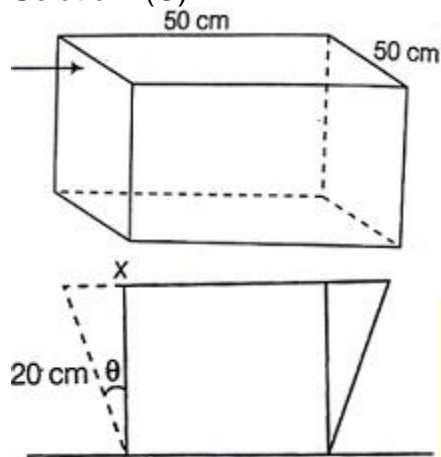

Shear strain,  $\epsilon = \tan \theta = \theta = \frac{x}{l}$

$$\eta = \frac{\sigma}{\epsilon}$$

$$\text{Or } x = \frac{F \cdot l}{A \cdot \eta}$$

Given  $F = 30N$

$$A = 50 \times 50 \times 10^{-4}$$

$$\eta = 4 \times 10^{10}$$

$$= \frac{30 \times 20 \times 10^{-2}}{50 \times 50 \times 10^{-4} \times 4 \times 10^{10}}$$

$$= \frac{24 \times 4 \times 10^{-4} \times 10^{10}}{-6}$$

$$= 6 \times 10^{-10}m$$

43. Initially a beaker has 100g of water at temperature  $90^{\circ}C$ . Later another 600g of water at temperature  $20^{\circ}C$  was poured into the beaker. The temperature,  $T$  of the water after mixing is

- (A)  $20^{\circ}C$
- (B)  $30^{\circ}C$
- (C)  $45^{\circ}C$
- (D)  $55^{\circ}C$
- (E)  $90^{\circ}C$

Solution: (B)

Given,

$$\text{Mass of water at } 90^{\circ}C = 100gm$$

$$= 100 \times 10^{-3}kg$$

$$\text{Mass of water at } 20^{\circ}C = 600 gm$$

$$= 600 \times 10^{-3}kg$$

From calorimetry

$$m_1 s_1 t_1 + m_2 s_2 t_2 = (m_1 + m_2) s \cdot T$$

$$\therefore s_1 t_1 + s_2 t_2 = s t$$

[where,  $T$  is temperature of mixture].

$$\begin{aligned}
& 100 \times 10^{-3} \times 1 \times 90 + 600 \times 10^{-3} \times 1 \times 20 \\
& = (100 + 600) \times 10^{-3} \times 1 \times T \\
T & = \frac{100 \times 10^{-3} \times 90 + 600 \times 10^{-3} \times 20}{700 \times 10^{-3}} \\
& = \frac{(900 + 12000) \times 10^{-3}}{700 \times 10^{-3}} \\
& = \frac{21000}{700} \\
& = 30^\circ\text{C}
\end{aligned}$$

44. Match the following

I	Isothermal process	1	$\Delta Q = 0$
II	Isobaric process	2	$\Delta V = 0$
III	Isochoric process	3	$\Delta P = 0$
IV	Adiabatic process	4	$\Delta T = 0$

- (A) I-4, II-3, III-2, IV-1  
 (B) I-3, II-2, III-1, IV-4  
 (C) I-1, II-2, III-3, IV-4  
 (D) I-4, II-2, III-3, IV-1  
 (E) I-1, II-4, III-2, IV-3

Solution: (A)

I-4	( $\because$ In isothermal process, temperature remains constant)
II-3	( $\because$ In isobaric process, pressure remains constant)
III-2	( $\because$ In isochoric process, volume remains constant)
IV-1	( $\because$ In adiabatic process, total heat of the system remains constant)

45. For an ideal gas, the specific heat at constant pressure  $C_p$  is greater than the specific heat at constant volume  $C_v$ . This is because

- (A) There is a finite work done by the gas on its environment when its temperature is increased while the pressure remains constant  
 (B) There is a finite work done by the gas on its environment when its temperature is increased while the volume remains constant  
 (C) There is a finite work done by the gas on its environment when its pressure is increased while the temperature remains constant  
 (D) The pressure of the gas remains constant when its temperature remains constant  
 (E) The internal energy of the gas at constant pressure is more than at constant volume



Solution: (A)

For an ideal gas, the specific heat at constant pressure  $C_p$  is greater than  $C_v$ . This is because some finite work has to be done by the gas on its environment when its temperature is increased while the pressure remains constant.

46. Which of the following statement is correct?

- (A) Light waves are transverse but sound waves are waves on strings are longitudinal
- (B) Sound waves and waves on a string and transverse but light waves are longitudinal
- (C) Light waves and waves on a string are transverse but sound waves are longitudinal
- (D) Light waves and sound waves are transverse but waves on string are longitudinal
- (E) Light waves, sound waves and waves on a string are all longitudinal

Solution: (C)

Light and waves on the string transverse but sound waves in air are longitudinal

47. In Young's double slits experiment, if the separation between the slits is halved, and the distance between the slits and the screen is doubled, then the fringe width compared to the original one will be

- (A) Unchanged
- (B) Halved
- (C) Doubled
- (D) Quadrupled
- (E) Fringes will disappear

Solution: (D)

The fringe width,

$$\beta = \frac{\lambda D}{d}$$

Where,  $\lambda$  = wavelength of light

$d$  = distance of slit

$D$  = distance of screen from slit.

According to question,

$$d' = \frac{d}{2}$$

$$D = 2D$$

$$\beta' = ?$$

$$\beta' = \frac{\lambda D'}{d'}$$

$$= \frac{\lambda 2D}{d/2} = 4\beta$$

So, the fringe width will be quadrupled.

48. The phase velocity of a wave described by the equations  $\psi = \psi_0 \sin(kx + \omega t + \pi/2)$  is

- (A)  $\frac{x}{t}$

- (B)  $\frac{\psi_0}{\omega}$
- (C)  $\frac{\psi}{k}$
- (D)  $\frac{\pi}{2k}$
- (E)  $\psi_0$

Solution: (C)

Given,

$$\psi = \psi_0 \sin\left(kx + \psi t + \frac{\pi}{2}\right)$$

Phase velocity of wave

$$v = \frac{\omega}{k} = \frac{\text{Angular frequency}}{\text{Propagation constant}}$$

49. The direction of propagation of electromagnetic wave is along

- (A) Electric field vector,  $E$
- (B) Magnetic field vector,  $B$
- (C)  $E \cdot B$
- (D)  $E \times B$
- (E)  $B \times E$

Solution: (D)

The direction of propagation of electromagnetic wave is always perpendicular to the plane in which  $E$  and  $B$  lies.

And,  $E \times B = C$

50. Assume that a radio station is about  $200\text{km}$  away at your location and the station operates  $972\text{ kHz}$ . How long does it take for an electromagnetic signal to travel from the station to you and how many wave crests does it send out per second?

- (A)  $666\ \mu\text{s}$  and  $9.72 \times 10^5$  crests per second
- (B)  $666\ \mu\text{s}$  and  $972 \times 10^5$  crests per second
- (C)  $555\ \mu\text{s}$  and  $97.2 \times 10^7$  crests per second
- (D)  $555\ \mu\text{s}$  and  $9.72 \times 10^5$  crests per second
- (E)  $444\ \mu\text{s}$  and  $9 \times 10^6$  crests per second

Solution: (A)

The speed of radio waves is equal to electromagnetic wave speed i.e.  $3 \times 10^8\ \text{m/s}$

Given, the distance of radio station,  $s = 200\ \text{km}$

$$= 200 \times 10^3\ \text{m}$$

Time taken by radio wave to his toner

$$t = \frac{s}{c} = \frac{200 \times 10^3}{3 \times 10^8}$$

$$= 666 \times 10^{-6}$$

$$= 666\ \mu\text{s}$$

The wave emitted send out per second =  $972\ \text{kHz}$

$$= 972 \times 10^3 \text{ Hz}$$

$$= 9.72 \times 10^5 \text{ crest per second}$$

51. What wavelength must electromagnetic radiation have if a photon in the beam has the same momentum as an electron moving with a speed  $1.1 \times 10^5 \text{ m/s}$  (Planck's constant =  $6.6 \times 10^{-34} \text{ J-s}$ , rest mass of electron =  $9 \times 10^{-31} \text{ kg}$ )

- (A)  $\frac{2}{3} \text{ nm}$
- (B)  $\frac{20}{3} \text{ nm}$
- (C)  $\frac{4}{3} \text{ nm}$
- (D)  $\frac{40}{3} \text{ nm}$
- (E)  $\frac{3}{20} \text{ nm}$

Solution: (B)

Given,

$$m_e = \text{mass of electron}$$

$$= 9 \times 10^{-31} \text{ kg}$$

$$= 101 \times 10^5 \text{ m/s}$$

$$\text{Momentum, } p = m_e v_e$$

$$p = 9 \times 10^{-31} \times 1.1 \times 10^5$$

$$= 9.9 \times 10^{-26} \text{ kg-m/s}$$

From de-Broglie waves

$$\lambda = \frac{h}{p} = \frac{6.6 \times 10^{-34}}{9.9 \times 10^{-26}} \text{ m}$$

$$= \frac{2}{3} \times 10^{-8} \text{ m}$$

$$= \frac{20}{3} \times 10^{-9} \text{ m} = \frac{20}{3} \text{ nm}$$

52. The electric field portion of an electromagnetic wave is given by (all variables in SI units)  $E = 10^{-4} \sin(6 \times 10^5 t - 0.01x)$ . The frequency ( $f$ ) and the speed ( $v$ ) of electromagnetic wave are

- (A)  $f = \frac{30}{\pi} \text{ kHz}$  and  $v = 1.5 \times 10^7 \text{ m/s}$
- (B)  $f = \frac{90}{\pi} \text{ kHz}$  and  $v = 6.0 \times 10^7 \text{ m/s}$
- (C)  $f = \frac{300}{\pi} \text{ kHz}$  and  $v = 6.0 \times 10^7 \text{ m/s}$
- (D)  $f = \frac{600}{\pi} \text{ kHz}$  and  $v = 7.5 \times 10^7 \text{ m/s}$
- (E)  $f = \frac{900}{\pi} \text{ kHz}$  and  $v = 8.0 \times 10^7 \text{ m/s}$

Solution: (C)

$$\omega = 6 \times 10^5 = 2\pi f$$

$$f = \frac{6}{2\pi} \times 10^5 = \frac{3}{\pi} \times 10^5 \text{ Hz}$$

$$\begin{aligned}
&= \frac{300}{\pi} \times 10^3 \text{ Hz} \\
&= \frac{300}{\pi} \text{ kHz} \\
\text{Wave speed} &= \frac{\omega}{k} \\
&= \frac{6 \times 10^5}{0.01} = 6 \times 10^7 \text{ m/s}
\end{aligned}$$

53. Huygens' wave theory of light cannot explain

- (A) Diffraction phenomena
- (B) Interference phenomena
- (C) Photoelectric effect
- (D) Polarization of light
- (E) Propagation of light

Solution: (C)

Huygen's wave theory of light cannot explain the photoelectric effect. Because it is due to particle nature of light.

54. An electron, a neutron and an alpha particle have same kinetic energy and their de-Broglie wavelength are  $\lambda_e, \lambda_n$  and  $\lambda_\alpha$  respectively. Which statement is correct about their de-Broglie wavelengths?

- (A)  $\lambda_e > \lambda_n > \lambda_\alpha$
- (B)  $\lambda_e < \lambda_n > \lambda_\alpha$
- (C)  $\lambda_e < \lambda_n < \lambda_\alpha$
- (D)  $\lambda_e > \lambda_n < \lambda_\alpha$
- (E)  $\lambda_e = \lambda_n < \lambda_\alpha$

Solution: (A)

According to de-Broglie theory, the wavelength

$$\lambda = \frac{h}{p} = \frac{h}{\sqrt{2mk}}$$

$$\lambda \propto \frac{1}{\sqrt{m}} \text{ (for same kinetic energy)}$$

The wavelength is inversely proportional to the root of mass of the particle.

As  $m_e < m_n < m_\alpha$

So,  $\lambda_e > \lambda_n > \lambda_\alpha$

55. It takes  $4.6 \text{ eV}$  to remove one of the least tightly bound electrons from a metal surface. When monochromatic photons strike the metal surface, electrons having kinetic energy from zero to  $2.2 \text{ eV}$  are ejected. What is the energy of the incident photons?

- (A)  $2.4 \text{ eV}$
- (B)  $2.2 \text{ eV}$
- (C)  $6.8 \text{ eV}$
- (D)  $4.6 \text{ eV}$
- (E)  $5.8 \text{ eV}$

Solution: (C)

According to question, the work function of the metal surface is  $W = 4.6 \text{ eV}$  and  $K.E$  of ejected electron =  $2.2 \text{ eV}$

Let the energy of incident photon is  $E$ .

$$\text{i.e. } E = W + K_e$$

$K_e$  = kinetic energy of ejected electrons

$$E = 4.6 \text{ eV} + 2.2 \text{ eV}$$

$$= 6.8 \text{ eV}$$

56. If copper and silicon pieces are heated, the resistance of

- (A) Each will increase
- (B) Each will decrease
- (C) Copper will increase and silicon will decrease
- (D) Copper will decrease and silicon will increase
- (E) Both does not change

Solution: (C)

When copper and silicon are heated the resistance of copper will increase and silicon will decrease as silicon is semiconductor.

57. In an insulator, band gap of the order of

- (A)  $0.1 \text{ eV}$
- (B)  $1 \text{ eV}$
- (C)  $5 \text{ eV}$
- (D)  $100 \text{ eV}$
- (E)  $1 \text{ MeV}$

Solution: (C)

In an insulator the forbidden band gap is of the order of  $5 \text{ eV}$

58. For a  $P - N$  junction diode

- (A) Forward current in  $\text{mA}$  and reverse current is in  $\mu\text{A}$
- (B) Forward current is in  $\mu\text{A}$  and reverse current is in  $\text{mA}$
- (C) Both forward and reverse currents are in  $\mu\text{A}$
- (D) Both forward and reverse currents are in  $\text{mA}$
- (E) No current flows in any direction

Solution: (A)

For a  $P - N$  junction diode, the forward current is in  $\text{mA}$  and reverse current is in  $\mu\text{A}$ . In forward bias the majority charge carriers drift in junction, while in reverse bias the majority charge carriers drift away from the junction, only minority charge carriers drift towards the junction.

59. For a Zener diode

- (A) Both  $p$  and  $n$  regions are heavily doped

- (B)  $p$  region is heavily doped but  $n$  region is lightly doped
- (C)  $n$  region is heavily doped but  $p$  region is lightly doped
- (D) Both  $p$  and  $n$  regions are lightly doped
- (E) Depletion region is very thick

Solution: (A)

Both  $p$  and  $n$  are heavily doped, so that breakdown occurs easily.

60. Speech signals is in the range of

- (A) 3700 Hz to 7000 Å wavelength
- (B) 20 Hz to 20 kHz frequency
- (C) 300 Hz to 3100 Hz frequency
- (D) 540kHz to 1600 kHz frequency
- (E) 88 MHz to 108 MHz frequency

Solution: (C)

The speech signal for human being is of 300 Hz to 3100 Hz frequency.

61. Wavelength of the wave with 30 MHz frequency is

- (A) 1 cm
- (B) 10 cm
- (C) 100 cm
- (D) 1000 cm
- (E) 10000 cm

Solution: (D)

Given,

Frequency  $\nu = 30 \text{ MHz}$

$$= 30 \times 10^6 \text{ Hz}$$

We know that,  $c = \nu\lambda$

$$\lambda = \frac{c}{\nu}$$

$$c = 3 \times 10^8 \text{ m/s}$$

$$\lambda = \frac{3 \times 10^8}{30 \times 10^6} = 10 \text{ m} = 1000 \text{ cm}$$

62. To transmit a signal of frequency  $\omega_m$ , with a carrier frequency  $\omega_c$ , in AM transmission, the bandwidth of the filter and amplifier is

- (A)  $\omega_m$
- (B)  $2\omega_m$
- (C)  $\omega_c$
- (D)  $\omega_c - \omega_m$
- (E)  $\omega_c + \omega_m$

Solution: (B)

Given, Transmitted frequency of signal =  $\omega_m$

Carrier frequency

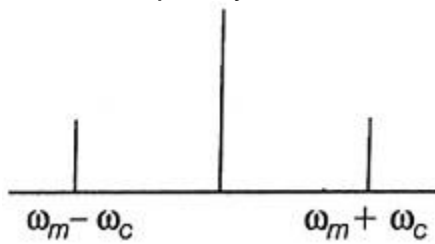

The band width of the filter and amplifier

$$= (\omega_m - \omega_c) + (\omega_m + \omega_c)$$

$$= 2 \omega_m$$

63. If a magnet is dropped through a vertical hollow copper tube, then

- (A) The time taken to reach the ground is longer than the time taken, if the tube was made out of plastic
- (B) The magnet will get attracted and stick to the copper tube
- (C) The time taken to reach the ground is longer than the time taken, if the tube was made out of stainless steel
- (D) The time taken to reach the ground does not depend on the radius of the copper tube
- (E) The magnet will be repelled away by the tube

Solution: (D)

When the magnet is dropped in a hollow copper tube vertically, the magnet will drop or fall under gravity only, so the time taken to reach the ground does not depend on the radius of copper tube.

64. Consider a circular wire loop of radius  $R$  spinning about a diametrical chord which is perpendicular to uniform magnetic field ( $B = B_0 \hat{k}$ )

- (A) The magnitude of the induced  $EMF$  in the loop is maximum when the plane of the loop is perpendicular to  $B$
- (B) Flux through the loop is maximum when the plane of the loop is perpendicular to  $B$
- (C) The direction of induced current remains same during the spinning motion of the loop
- (D)  $EMF$  induced will be the same for a larger radius of the loop in the same field
- (E) No  $EMF$  will be induced since magnetic field is constant

Solution: (A)

Given,  $B = B_0 \hat{k}$

The induced e.m.f,

$$e = -\frac{d\phi}{dt} = -\frac{d(BA)}{dt}$$

$$= -B \frac{dA}{dt}$$

$$\therefore \phi = (B.A)$$

So, the flux linked with the circular loop of radius will be maximum, when its plane is perpendicular to the magnetic field, then the induced e.m.f will be maximum.

65. An electric motor which loaded has an effective resistance of  $30\Omega$  and an inductive reactance of  $40\Omega$ . If the motor is powered by a source with maximum voltage of  $420\text{ V}$ , the maximum current is

- (A)  $6\text{ A}$
- (B)  $8.4\text{ A}$
- (C)  $10\text{ A}$
- (D)  $12\text{ A}$
- (E)  $13\text{ A}$

Solution: (B)

Given,

Effective resistance,  $R = 30\Omega$

Inductive reactance,  $X_L = 40\Omega$

The effective impedance

$$\begin{aligned} Z &= \sqrt{R^2 + X_L^2} \\ &= \sqrt{(30)^2 + (40)^2} \\ &= \sqrt{900 + 1600} \\ &= \sqrt{2500} \\ &= 50\Omega \end{aligned}$$

The maximum current,

$$\begin{aligned} I &= \frac{V}{Z} \\ &= \frac{420}{50} \\ &= 8.4\text{ A} \end{aligned}$$

66. Which of the following particle when bombards on  ${}^{65}\text{Cu}$  will turn into  ${}^{66}\text{Cu}$ ?

- (A) Proton
- (B) Neutron
- (C) Electron
- (D) Alpha particle
- (E) Deutron

Solution: (B)

When  ${}^{65}\text{Cu}$  is bombard with neutron, the neutron is absorbed in  ${}^{65}\text{Cu}$  and turn into  ${}^{66}\text{Cu}$ .

67.  $\text{CO}^-$  ion moving with kinetic energy of  $20\text{ keV}$  dissociates into  $\text{O}^-$  and  $\text{C}$  which move along the parent ion direction. Assuming no energy is released during dissociation, the kinetic energy of the daughters  $(K.E)_{\text{O}^-}$  and  $(K.E)_{\text{C}}$  are related as

- (A)  $(K.E)_{\text{O}^-} = (K.E)_{\text{C}}$
- (B)  $(K.E)_{\text{O}^-} / (K.E)_{\text{C}} = 16/12$



- (C)  $(K.E)_{O^-}/(K.E)_C = 12/161$   
 (D)  $(K.E)_{O^-}/(K.E)_C = 16/28$   
 (D)  $(K.E)_{O^-}/(K.E)_C = 28/16$

Solution: (C)

As no energy is released, lighter particle carries more  $K.E$

$$\therefore K.E \propto \frac{1}{\text{mass}}$$

$\therefore$  Molar mass of carbon = 12

Molar mass of oxygen = 16

Thus, they are related as

$$\frac{K_O}{K_C} = \frac{\text{Molar mass of carbon}}{\text{Molar mass of oxygen}}$$

$$= \frac{12}{16}$$

68. If the rms value of sinusoidal input to a full wave rectifier is  $\frac{V_0}{\sqrt{2}}$ , then the rms value of the rectifier's output is

- (A)  $\frac{V_0}{\sqrt{2}}$   
 (B)  $\frac{V_0^2}{\sqrt{2}}$   
 (C)  $\frac{V_0^2}{2}$   
 (D)  $\sqrt{2} V_0^2$   
 (E)  $2V_0^2$

Solution: (A)

Given,

$$\text{Input } V_{\text{rms}} = \frac{V_0}{\sqrt{2}}$$

Where,  $V_0$  = Peak value of voltage

In full wave rectifier, the whole cycle is rectified, so the value of input voltage will be same as output.

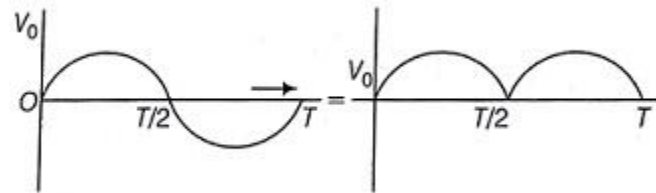

So, the output voltage will be  $\frac{V_0}{\sqrt{2}}$

69. 8 g of  $\text{Cu}^{66}$  undergoes radioactive decay and after 15 minutes only 1g remains. The half-life, in minutes, is then

- (A)  $15 \ln(2)/\ln(8)$   
 (B)  $15 \ln(8)/\ln(2)$   
 (C) 15/8

- (D)  $8/15$
- (E)  $15 \ln(2)$

Solution: (A)

Given,

$$m_0 = 8g$$

$$m = 1g$$

Time of decay = 15 min

$$\ln \frac{M}{M_0} = \lambda t$$

$$\Rightarrow \ln \left( \frac{1}{8} \right) = \lambda(15)$$

$$\therefore \lambda = \frac{\ln 8}{15}$$

$$\text{So, } T_{1/2} = \frac{\ln 2}{\lambda}$$

$$= \frac{15 \ln 2}{\ln 8}$$

70. For a light nuclei, which of the following relation between the atomic number ( $Z$ ) and mass number ( $A$ ) is valid?

- (A)  $A = Z/2$
- (B)  $Z = A$
- (C)  $Z = A/2$
- (D)  $Z = A^2$
- (E)  $A = Z^2$

Solution: (C)

Given,

Atomic number =  $Z$

Mass number =  $A$

For lighter nuclei, the relation between  $Z$  and  $A$  is

$$Z = \frac{A}{2}$$

71. A wheel rotating at  $12 \text{ rev/s}$  is brought to rest in  $6 \text{ s}$ . The average angular deceleration in  $\text{rad/s}^2$  of the wheel during this process is

- (A)  $4\pi$
- (B)  $4$
- (C)  $72$
- (D)  $\frac{1}{\pi}$
- (E)  $\pi$

Solution: (A)

$$w_1^0 = 12 \times 2\pi \frac{\text{rad}}{\text{s}}$$

$$= 24\pi \frac{\text{rad}}{\text{s}}$$

$$w_f = 0$$

$$\Delta t = 6\text{s}$$

$$\text{As } w_f = w_1 + \alpha \Delta t$$

$$\text{We have, } \alpha = \frac{-w_i}{\Delta t}$$

$$= -\frac{24\pi}{6}$$

$$= -4\pi \frac{\text{rad}}{\text{sec}^2}$$

72. A torque of  $1 \text{ N} \cdot \text{m}$  is applied to a wheel which is at rest. After 2 second the angular momentum in  $\text{kg} \cdot \text{m}^2/\text{s}$  is

(A) 0.5

(B) 1

(C) 2

(D) 4

(E) 3

Solution: (C)

$$\text{As; } \tau = I\alpha$$

$$\text{So, } \alpha = \frac{\tau}{I}$$

$$\text{Now } w = \alpha \Delta t$$

$$\text{And } L = Iw$$

$$= I\alpha \Delta t$$

$$= I \frac{\tau}{I} \Delta t = \tau \Delta t$$

$$= 1(\text{N} \cdot \text{m}) \times 2(\text{s})$$

$$= 2 \text{ kgm}^2\text{s}^{-1}$$

# Chemistry

## Single correct answer type:

1. Uncertainty principle is valid for

- (A) Proton
- (B) Methane
- (C) Both (Proton) and (Methane)
- (D)  $1\mu\text{m}$  sized platinum particles
- (E)  $1\mu\text{m}$  sized  $\text{NaCl}$  particles

Solution: (A)

According to uncertainty principle the position and momentum for a sub-atomic particle (i.e. of very small mass) is uncertain to find simultaneously. Thus, uncertainty principle is valid for protons. (Sub-atomic particle)

2. The energy of an electron in the 3S orbital (excited state) of H –atom is

- (A)  $-1.5\text{eV}$
- (B)  $-13.6\text{eV}$
- (C)  $-3.4\text{eV}$
- (D)  $-4.53\text{eV}$
- (E)  $4.53\text{eV}$

Solution: (A)

(i) Energy ( $E$ ) of  $n = 1$  i.e. is,

$$= -\frac{13.6 \cdot z^2}{n^2} \text{eV}$$

$$= -\frac{13.6 \times 1}{1} = -13.6 \text{eV}$$

(ii) For  $n = 3$  i.e. 3s

$$E = -\frac{13.6}{(3)^2}$$

$$= -\frac{13.6}{9} \text{eV}$$

$$= 1.5 \text{eV}$$

3. Among the following, the molecule that will have the highest dipole moment is

- (A)  $\text{H}_2$
- (B)  $\text{HI}$
- (C)  $\text{HBr}$

- (D)  $HCl$   
(E)  $HF$

Solution: (E)

$\therefore$  Dipole moment  $\propto$  Difference in electronegativity of the bonded atoms.

As maximum electronegativity difference is shown by  $H - F$ .

( $\therefore H$  is constant and  $F$  has maximum electronegativity).

Hence, i.e.  $HF$  will show highest dipole moment.

4. Which of the following pair have identical bond order?

- (A)  $CN^-$  and  $NO^+$   
(B)  $CN^-$  and  $O_2^-$   
(C)  $CN^-$  and  $CN^+$   
(D)  $NO^+$  and  $O_2^-$   
(E)  $O_2^-$  and  $CN^+$

Solution: (A)

For pairs having identical bond order, have identical number of electrons

Number of electrons for  $CN^- = 6 + 7 + 1 = 14$

Number of electrons for  $NO^+ = 7 + 8 - 1 = 14$

Number of electrons for  $O_2^- = 8 + 8 + 1 = 17$

Hence,  $CN^-$  and  $NO^+$  have same bond order.

5. A gas will approach ideal behavior at

- (A) Low temperature and low pressure  
(B) Low temperature and high pressure  
(C) High temperature and low pressure  
(D) High temperature and high pressure  
(E) Low volume and high pressure

Solution: (C)

For a gas to show ideal behavior, the attractive force between the gas molecules must be negligible.

Also, at high temperature and low pressure, the attractive forces between the gas molecules becomes negligible.

6. Pressure of ideal and real gases at  $0K$  are

- (A)  $> 0$  and  $0$   
(B)  $< 0$  and  $0$   
(C)  $0$  and  $0$   
(D)  $> 0$  and  $> 0$   
(E)  $0$  and  $> 0$

Solution: (E)

(i)  $\therefore$  For: ideal gas  $Z = 1, pV = nRT$

Or  $\frac{pV}{nRT} = 1(Z)$

For <b>real gas</b>  $Z \neq 1$  i.e.  $P > 0$ .

(ii) For ideal gas,

Temperature must be high and pressure must be low i.e.

Pressure = 0 (or negligible)

Temperature  $> 0$  (or high)

7. For the process  $A(1, 0.05 \text{ atm}, 32^\circ\text{C}) \rightarrow A(g, 0.05 \text{ atm}, 32^\circ\text{C})$

The correct set of thermodynamic parameters is

(A)  $\Delta G = 0$  and  $\Delta S = -ve$

(B)  $\Delta G = 0$  and  $\Delta S = +ve$

(C)  $\Delta G = +ve$  and  $\Delta S = 0$

(D)  $\Delta G = -ve$  and  $\Delta S = 0$

(E)  $\Delta G = 0$  and  $\Delta S = 0$

Solution: (B)

(i)  $\because n$  and  $T$  are constant.

$\therefore \Delta G = 0$  i.e.

System is equilibrium

(ii)  $\because P \rightarrow$  decreases

$\therefore \Delta S \rightarrow$  increases i.e.  $(+)ve$

8. Mixing of  $N_2$  and  $H_2$  from an ideal gas mixture at room temperature in a container.

For this process, which of the following statement is true?

(A)  $\Delta H = 0, \Delta S_{\text{surrounding}} = 0, \Delta S_{\text{system}} = 0$  and  $\Delta G = -ve$

(B)  $\Delta H = 0, \Delta S_{\text{surrounding}} = 0, \Delta S_{\text{system}} > 0$  and  $\Delta G = -ve$

(C)  $\Delta H > 0, \Delta S_{\text{surrounding}} = 0, \Delta S_{\text{system}} > 0$  and  $\Delta G = -ve$

(D)  $\Delta H < 0, \Delta S_{\text{surrounding}} > 0, \Delta S_{\text{system}} < 0$  and  $\Delta G = -ve$

(E)  $\Delta H = 0, \Delta S_{\text{surrounding}} = 0, \Delta S_{\text{system}} < 0$  and  $\Delta G = -ve$

Solution: (D)

(i)  $\because N_{2(g)} + 3H_{2(g)} \rightleftharpoons 2NH_{3(g)}$ ,

$\Delta H = (-)ve$

Favourable condition—Low temperature

And  $\Delta n = 2 - 4 = (-)2$  i.e.  $(-)ve$

Also

(ii)  $\because \Delta S_{\text{(univ.)}} = \Delta S_{\text{(surrounding)}} + \Delta S_{\text{(system)}}$

And for  $\Delta G$  to be  $(-)ve$ , i.e. (spontaneous) at room temperature,

$\Delta H < 0$

$\Delta S_{\text{(surrounding)}} > 0$

$\Delta S_{\text{(system)}} < 0$  and  $\Delta S_{\text{(univ.)}} > 0$

9. Which of the following is not true about a catalyst?

(A) Mechanism of the reaction in presence and absence of catalyst could be different

(B) Enthalpy of the reaction does not change with catalysts

(C) Catalyst enhances both forward and backwards reaction at equal rate

- (D) Catalyst participates in the reaction, but not consumed in the process  
 (E) Use of catalyst cannot change the order of the reaction

Solution: (E)

The catalyst

- (i) If not present may give a different product.  
 (ii) Will not change the net enthalpy of the reaction.  
 (iii) Can enhance both forwards and backward reactions.  
 (iv) Will participate in the reaction but not get consumed.  
 (v) Use of a catalyst may change the order.

10. In the  $\ln K$  vs.  $\frac{1}{T}$  plot of a chemical process having  $\Delta S^\circ > 0$  and  $\Delta H^\circ < 0$  the slope is proportional to (where  $K$  is equilibrium constant)

- (A)  $-|\Delta H^\circ|$   
 (B)  $|\Delta H^\circ|$   
 (C)  $\Delta S^\circ$   
 (D)  $-\Delta S^\circ$   
 (E)  $\Delta G^\circ$

Solution: (B)

$$\therefore \log K = \log A - \frac{Ea}{2.303R} \cdot \frac{1}{T}$$

$$\text{And } \Delta G = \Delta H - T\Delta S = 2.303 RT \log K$$

On plotting the graph between  $\frac{1}{T}$  and  $\log K$  using straight line equation

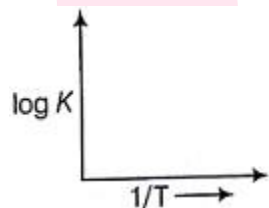

$$y = mx + c$$

$$\log k \propto \frac{1}{T}$$

If  $\Delta S^\circ > 0$  and  
 $\Delta H^\circ < 0$  then

The slope is proportional to  $|\Delta H^\circ|$

11. For the process

$\frac{3}{2}A \rightarrow B$ , at 298 K,  $\Delta G^\circ$  is  $163 \text{ kJ mol}^{-1}$ . The composition of the reaction mixture is  $[B] = 1$  and  $[A] = 10000$ . Predict the direction of the reaction and the relation between reaction quotient ( $Q$ ) and the equilibrium constant ( $K$ )

- (A) Forwards direction because  $Q > K$   
 (B) Reverse direction because  $Q > K$   
 (C) Forward direction because  $Q < K$   
 (D) Reverse direction because  $Q < K$

(E) It is at equilibrium as  $Q = K$

Solution: (C)

$$Q = \frac{[\text{conc. of product}]^n}{[\text{conc. of reactant}]^n} = \frac{[B]}{[A]}$$

$$Q = \frac{1}{[10000]^{\frac{3}{2}}}$$

Also,  $\Delta G = 2.303 RT \log K$

$$63 \times 1000 = 2.303 \times 8.314 \times 298 \log K$$

$$\therefore \log K = \frac{163 \times 1000}{2.303 \times 8.314 \times 298} = \frac{163000}{5705.8}$$

$$\approx 28.57$$

i.e.  $K > Q$  means

Forward reaction is favoured with  $Q < K$ .

12. Solubility product ( $K_{sp}$ ) of saturated  $PbCl_2$  in water is  $1.8 \times 10^{-4} \text{ mol}^3 \text{ dm}^{-9}$ . What is the concentration of  $Pb^{2+}$  in the solution?

(A)  $(0.45 \times 10^{-4})^{\frac{1}{3}} \text{ mol dm}^{-3}$

(B)  $(1.8 \times 10^{-4})^{\frac{1}{3}} \text{ mol dm}^{-3}$

(C)  $(0.9 \times 10^{-4})^{\frac{1}{3}} \text{ mol dm}^{-3}$

(D)  $(2.0 \times 10^{-4})^{\frac{1}{3}} \text{ mol dm}^{-3}$

(E)  $(2.45 \times 10^{-4})^{\frac{1}{3}} \text{ mol dm}^{-3}$

Solution: (A)

For the reaction of the  $AB_2$  i.e. ( $PbCl_2$ )

$$K_{sp} = 4s^3$$

$$\text{Or, } s = \left[ \frac{K_{sp}}{4} \right]^{\frac{1}{3}}$$

$$\text{Given, } K_{sp} = 1.8 \times 10^{-4} \text{ mol}^3 \text{ dm}^{-9}$$

$\therefore$  Solubility of  $Pb^{2+}$  ions will be

$$\therefore s = \left[ \frac{1.8 \times 10^{-4}}{4} \right]^{\frac{1}{3}}$$

$$= [0.45 \times 10^{-4}]^{\frac{1}{3}} \text{ mol. dm}^{-3}$$

13. The freezing point of equimolal solution will be highest for

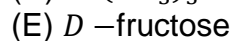
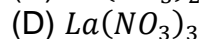
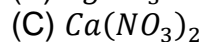
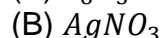
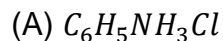

Solution: (E)



For Equimolal solution

- (i) Colligative property means  $\propto$  number of particles after dissociation or association.  
Less be the number of particles, more be the melting point and more be the number of particles, more lower be the melting in melting point.
- (ii) As number of particles for  $D$  –fructose is minimum  
( $\because$  It will not dissociate). The lowering in freezing point is least i.e. has highest freezing point.

14. The molality of the 3M solution of methanol if the density of the solution is  $0.9 \text{ g cm}^{-3}$  is

- (A) 3.73  
(B) 3.0  
(C) 3.33  
(D) 3.1  
(E) 3.2

Solution: (A)

$$\therefore \text{Molarity } (C) = \frac{W_B(\%) \times d \times 10}{M_B}$$

And

$$\text{Molality } (m) = \frac{W_B(\%) \times 1000}{[100 - W_B(\%)] \times M_B}$$

Where,  $W_B$  = mass of solute

$M_B$  = molar mass of solute

$W_B$  = to find,

$M_B$  = mass of  $\text{CH}_3\text{OH}$

$$= 32(12 + 3 + 16 + 1)$$

$$\therefore W_B(\%) = \frac{C \times M_B}{d \times 10}$$

$$= \frac{3 \times 32}{0.9 \times 10} = 10.66\text{g}(\%)$$

$$\text{And } m = \frac{W_B(\%) \times 1000}{[100 - 10.66] \times 32} = \frac{10.66 \times 1000}{89.34 \times 32}$$

$$m = 3.728 \approx 3.73 \text{ m}$$

15. Consider a fuel cell supplied with 1 mol of  $\text{H}_2$  gas and 10 moles of  $\text{O}_2$  gas. If fuel cell is operated at 9.63 mA current, how long will it deliver power?

(Assume  $1F = 96500 \text{ C/mole of electrons}$ )

- (A)  $1 \times 10^6 \text{ s}$   
(B)  $0.5 \times 10^6 \text{ s}$   
(C)  $2 \times 10^6 \text{ s}$   
(D)  $4 \times 10^6 \text{ s}$   
(E)  $5 \times 10^6 \text{ s}$

Solution: (C)

(i)  $\because w = zit$

$$\text{And } z = \frac{\text{At. wt.}}{nF}$$

(ii) Also,

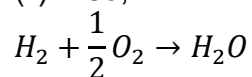

Given, 1 mol of  $H_2$

10 mol of  $O_2$

Thus by 1 mole of  $H_{2(g)}$ , we get 1 mol of  $H_2O$

Hence  $n = 2$

$$i = 96.5 \text{ mA} = 0.0965 \text{ A}$$

$$t(\text{time}) = \frac{w}{zi} = \frac{w}{\frac{\text{At. wt.}}{nF} \times i} = \frac{nF}{i}$$

$$t(\text{in sec}) = \frac{2 \times 96500}{0.0965} = 2 \times 10^6 \text{ sec}$$

16. Consider the equilibrium obtained by electrically connecting zinc-amalgam  $Zn(Hg)$  and  $HgO$  electrodes in mercury cell,

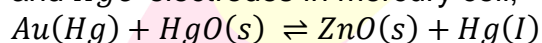

Under this equilibrium, what is the relation between the potential of the  $Zn(Hg)$  and  $HgO$  electrodes measured against the standard hydrogen electrode?

- (A)  $Zn(Hg)$  electrode potential is equal to  $HgO$  electrode potential
- (B)  $Zn(Hg)$  electrode potential is more than  $HgO$  electrode potential
- (C)  $HgO$  electrode potential is more than  $Zn(Hg)$  electrode
- (D) Cell voltage at above said equilibrium is 1.35 V
- (E) Both ( $HgO$  electrode potential is more than  $Zn(Hg)$  electrode) and (Cell voltage at above said equilibrium is 1.35 V)

Solution: (A)

Since, at equilibrium  $E_{(\text{cell})}^o = \text{zero}$

$$\text{And } E_{(\text{cell})}^o = E_{(\text{cathode})}^o - E_{(\text{anode})}^o$$

At equilibrium

$$E_{(\text{cathode})}^o = E_{(\text{anode})}^o \text{ i.e.}$$

Electrode potential of  $Zn(Hg)$  electrode must be equal to the  $HgO$  electrode.

17. 10g of  $MgCO_3$  decomposes on heating to 0.1 mole  $CO_2$  and 4g  $MgO$ . The percent purity of  $MgCO_3$  is

- (A) 24%
- (B) 44%
- (C) 54%
- (D) 74%
- (E) 84%

Solution: (E)

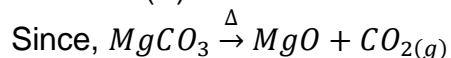

Mole ratio 1 : 1 : 1

Mass ratio (ing) 84 : 40 : 44

Given values 10g 4g 0.1 mol

$$(= 4.4 g) \left\{ \because n = \frac{w}{m} \right\}$$

(i)  $\therefore 84g$  of  $MgCO_3$  give  $MgO = 40g$

$$\therefore 10g \text{ of } MgCO_3 \text{ give } MgO = \frac{40 \times 10}{84} = 4.76g$$

Thus,  $MgO$  obtained is less by

$$4.76 - 4.0 = 0.76g$$

(ii)  $\therefore 84g$  of  $MgCO_3$  give  $CO_2 = 44g$

$$\therefore 10g \text{ of } MgCO_3 \text{ give } CO_2 = \frac{40 \times 10}{84} = 5.23g$$

Thus,  $CO_2$  obtained is less by  $5.23 - 4.4 = 0.84g$

$$\text{Total short} = 0.76 + 0.84 = 1.59 = 1.60$$

$\therefore 10g$  of  $MgCO_3$  give less products by  $= 1.60g$

$\therefore 100g$  of  $MgCO_3$  give less products by  $= 1.600g$

Hence,  $MgCO_3 = 100 - 16 = 84\%$

18. The compound  $Na_2CO_3 \cdot xH_2O$  has 50%  $H_2O$  by mass. The value of "x" is

(A) 4

(B) 5

(C) 6

(D) 7

(E) 8

Solution: (C)

(i)  $\therefore$  Molar mass of  $Na_2CO_3 = 106$  unit

$$(23 \times 2) + 12 + (3 \times 16)$$

And  $CO_3^{2-}$  has two (-) charge

While two  $Na^+$  ions are involved.

(ii) Number of moles (per unit charge) = 50% of 106 is  $\frac{106}{2} = 53g$

$$= \frac{53}{18}$$

$$= 2.94 \text{ mol}$$

$$\text{Total moles of } H_2O = 2 \times 2.94 \equiv 5.89 \approx 6.00$$

19. Hybridisation of carbon is  $CH_3^-$

(A)  $sp^2$

(B)  $sp^3$

(C)  $sp^3d$

(D)  $sp^3d^2$

(E)  $sp^2d^3$

Solution: (B)

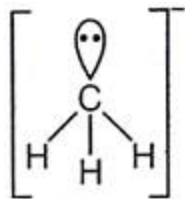

Structure for  $CH_3^-$

Total hybrid orbitals = Number of bonds + Number of lone pair of electrons.

$$= 3 + 1 = 4$$

Hence, hybridization =  $sp^3$

20. The common features among  $CO$ ,  $CN^-$  and  $NO_2^+$  are

- (A) Bond order three and isoelectronic
- (B) Bond order three and weak field ligands
- (C) Bond order two and  $\pi$ -acceptors
- (D) Bond order three and  $\pi$ -donors
- (E) Isoelectronic and strong field ligands

Solution: (A)

For the species having same number of electrons, have same bond order.

$$\text{Number of electrons for } CO = 6 + 8 = 14$$

$$\text{Number of electrons for } CN^- = 6 + 7 + 1 = 14$$

$$\text{Number of electrons from } NO^+ = 7 + 8 - 1 = 14$$

Hence, all the given species are iso-electronic and have same bond-order (three)

21. Which of the following is covalent?

- (A)  $NaCl$
- (B)  $KCl$
- (C)  $BeCl_2$
- (D)  $MgCl_2$
- (E)  $CaCl_2$

Solution: (C)

As we move down in the second group, metallic character increases. First member of  $2^{nd}$  group i.e. Be form covalent compounds preferentially (due to its small size).

Also, halides of  $Na$  and  $K$  are ionic in nature.

22. One mole of an unknown compound was treated with excess water and resulted in the evolution of two moles of a readily combustible gas. The resulting solution was treated with  $CO_2$  and resulted in the formation of white turbidity. The unknown compound is

- (A)  $Ca$
- (B)  $CaH_2$
- (C)  $Ca(OH)_2$
- (D)  $Ca(NO_3)_2$

(E)  $CaSO_4$

Solution: (B)

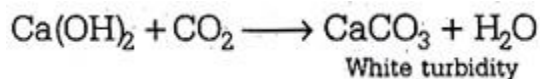
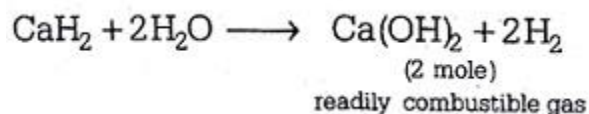

23. When potassium is reacted with water which compound(s) is are formed preferentially?

- (A)  $K_2O$
- (B)  $KO_2$
- (C) Both  $K_2O$  and  $KO_2$
- (D)  $K_2O_2$
- (E)  $K_2O_3$

Solution: (B)

Due to large size of Potassium (K) atom, it preferentially accommodate and form the bonds with two small oxygen atoms to give  $KO_2$ .

Hence,  $KO_2$  is the preferential product when potassium react with water.

24. Purification of aluminium by electrolytic refining is called

- (A) Hall's process
- (B) Froth flotation process
- (C) Bayer's process
- (D) Hoop's process
- (E) Serpeck's process

Solution: (D)

Hoop's process is used for purification of aluminium by electrolytic refining.

25. Select the most appropriate statement in  $BF_3$

- (A) All the bonds are completely ionic
- (B) The  $B - F$  bond is partially ionic
- (C)  $B - F$  bond has partial double bond character
- (D) Bond energy and bond length data indicates single bond character of the  $B - F$  bond
- (E) All the bonds are covalent

Solution: (E)

$BF_3$  is a covalent compound. Boron has 3 valency electrons with number  $d$ -orbital. Fluorine also have number  $d$ - orbital with 7 valency electrons. Thus Boron will form three covalent bonds with three fluorine atoms to complete its octate and give a stable  $BF_3$  molecule.

Hence,  $BF_3$  is a covalent compound.

26. The inert gas found most abundant in the atmosphere is

- (A)  $He$
- (B)  $Ne$
- (C)  $Ar$
- (D)  $Kr$
- (E)  $Xe$

Solution: (C)

The most abundant inert gas in the atmosphere is argon ( $Ar$ ).

27. When  $MnO_2$  is fused with  $KOH$  and  $KNO_2$ , a coloured compound is formed. Choose the right compound with the appropriate colour

- (A)  $K_2MnO_4$ , green
- (B)  $KMnO_4$ , purple
- (C)  $Mn_2O_3$ , brown
- (D)  $Mn_3O_4$ , black
- (E)  $MnO_2$ , black

Solution: (A)

When  $MnO_2$  react with fused mixture of  $KOH$  and  $KNO_3$ , it gives  $K_2MnO_4$ (green) as follows

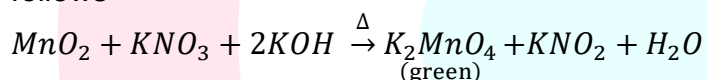

28. identify the case (s) where there is change is oxidation number

- (A) Acidified solution of  $CrO_4^{2-}$
- (B)  $SO_2$  gas bubbled through an acidic solution  $Cr_2O_7^{2-}$
- (C) Alkaline solution of  $Cr_2O_7^{2-}$
- (D) Ammoniacal solution of  $CrO_4^{2-}$
- (E) Aqueous solution of  $CrO_2Cl_2$  in  $NaOH$

Solution: (B)

When  $SO_2$  gas bubbled through acidic solution of  $Cr_2O_7^{2-}$ , it reacts as follows

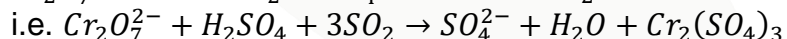
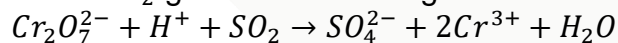

In above reaction chromium changes its oxidation number from +6 to +3 (red) and sulphur get oxidized.

29. Water gas is produced by

- (A) Passing steam over red hot coke
- (B) Passing steam and air over red hot
- (C) Burning coke in excess air
- (D) Burning coke in limited supply of air
- (E) Both (Passing steam over red hot coke) and (Passing steam and air over red hot)

Solution: (A)

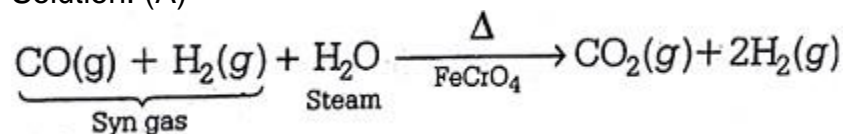

The chemical reaction in which carbon monoxide of syn-gas react with steam to give  $\text{CO}_2(g)$  is called water gas.

30. The volume of oxygen liberated at STP from 15 mL of 20 volume  $\text{H}_2\text{O}_2$  is

- (A) 100 mL
- (B) 150 mL
- (C) 200 mL
- (D) 250 mL
- (E) 300 mL

Solution: (E)

20 – vol  $\text{H}_2\text{O}_2$  means

1 mL of  $\text{H}_2\text{O}_2$  of 20 volume gives = 15 × 20 mL of  $\text{O}_2$  at STP

Thus, 15 mL of  $\text{H}_2\text{O}_2$  of 20 volume gives = 15 × 20 mL of  $\text{O}_2$  at STP

Volume of  $\text{O}_2$  at STP = 300 mL

31. Corundum is ..... mineral of aluminium.

- (A) Silicate
- (B) Oxide
- (C) Double salt
- (D) Sulphate
- (E) Nitrate

Solution: (B)

Corundum is oxide mineral of aluminium having formula  $\text{Al}_2\text{O}_3$ .

32. The solution which does not produce precipitate when treated with aqueous  $\text{K}_2\text{CO}_3$  is

- (A)  $\text{BaCl}_2$
- (B)  $\text{CaBr}_2$
- (C)  $\text{MgCl}_2$
- (D)  $\text{Na}_2\text{SO}_4$
- (E)  $\text{Pb}((\text{N})_3)_2$

Solution: (D)

As  $\text{Na}_2\text{SO}_4$  and  $\text{K}_2\text{CO}_3$  both are ionic compounds having same valency electrons, thus aqueous  $\text{K}_2\text{CO}_3$  will not produce precipitate with  $\text{Na}_2\text{SO}_4$ .

33. If the boiling point difference between that two liquids is not much, the ..... method is used to separate them

- (A) Simple distillation
- (B) Distillation under reduced pressure
- (C) Steam distillation
- (D) Fractional distillation
- (E) Differential extraction

Solution: (D)

When difference in boiling points between the two liquids is not much, **differential extraction** is the most suitable method to separate them. The liquid with lower density floats over the liquid having higher density, thus can be easily separated.

34. Lassaigne's test (with silver nitrate) is commonly used to detect halogens such as chlorine, bromine and iodine but not useful to detect fluorine because the product  $AgF$  formed is

- (A) Volatile
- (B) Reactive
- (C) Explosive
- (D) Soluble in water
- (E) A liquid

Solution: (D)

As  $AgF$  is soluble in Lassaigne's solution (silver nitrate solution), it will not give any precipitate.

35. Protein is a polymer made of

- (A) Carbohydrates
- (B) Amino acids
- (C) Nucleic acids
- (D) Carboxylic acids
- (E) Polycyclic aromatics

Solution: (B)

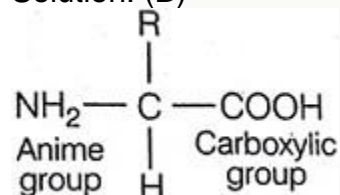

Protein is a polymer, made of amino acids, the monomer of protein (i.e. a single amino acid) contain both the groups i.e. amine and carboxylic group in its molecule e.g.

36. The letter 'D' in D-carbohydrates represents

- (A) Dextrorotation
- (B) Direct synthesis
- (C) Configuration
- (D) Mutarotation
- (E) Optical activity



Solution: (C)

'D' and 'L' indicates relative configuration of a particular carbohydrate.

'D' represent the position of 2nd last -OH group in any carbohydrate

If the 2nd last -OH is present on the right side it is called 'D' type configuration and if present to the left-side, it is called 'L' type configuration.

37. Phenol is a highly corrosive substance, but its 0.2 percent solution is used as

- (A) Antibiotic
- (B) Antiseptic
- (C) Disinfectant
- (D) Antihistamine
- (E) Antacide

Solution: (B)

0.2% phenol solution is used as antiseptic.

38. Name of the following reaction is

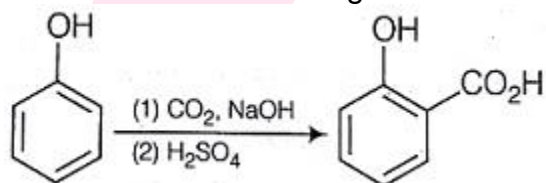

- (A) Reimer-Tiemann
- (B) Kolbe-Schmitt
- (C) Cannizzaro
- (D) Gattermann
- (E) Gattermann-Koch

Solution: (B)

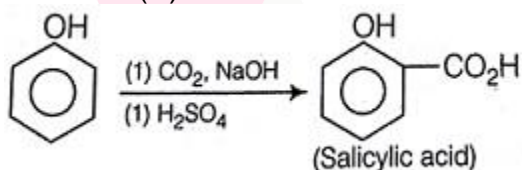

The given reaction is known as, Kolbe's-Schmidt reaction. It is used to get salicylic acid.

39. X and Y in the below reaction are ..... and ..... Respectively

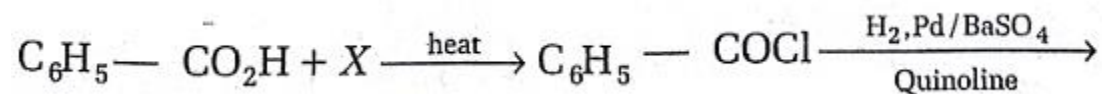

- (A)  $\text{SOCl}_2$  and  $\text{C}_6\text{H}_5\text{CHO}$
- (B)  $(\text{COCl})_2$  and  $\text{C}_6\text{H}_5\text{CH}_3$

- (C)  $SOCl_2$  and  $C_6H_5CH_3$   
 (D)  $(COCl)_2$  and  $C_6H_5CH_2OH$   
 (E)  $SOCl_2$  and  $C_6H_5CH_2Cl$

Solution: (A)

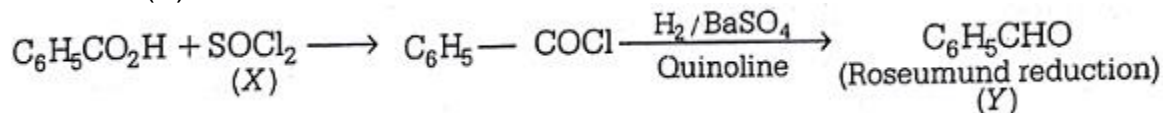

$\therefore$  (X) and (Y) are  $SOCl_2$  and  $C_6H_5CHO$  respectively.

40. The reaction of propene with  $HBr$  in the presence of peroxide proceeds through the intermediate

Solution: (B)

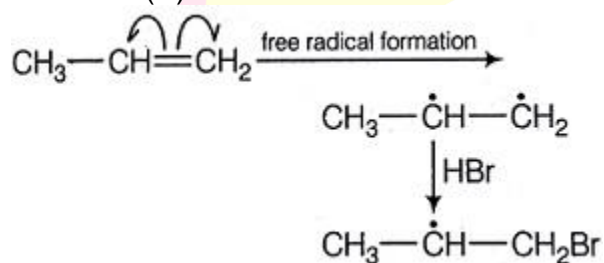

The intermediate produced in case of addition of  $HBr$  occurs according to anti-Markovnikov's rule. Thus we get

41. The major product  $P$  formed in the following reaction is

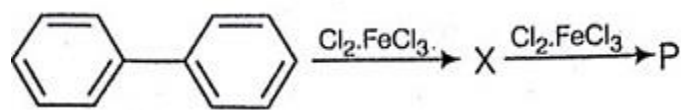

(A)

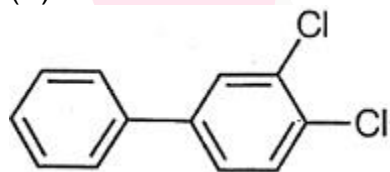

(B)

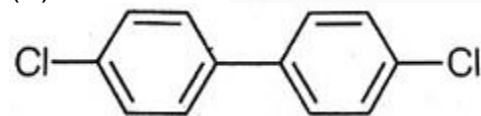

(C)

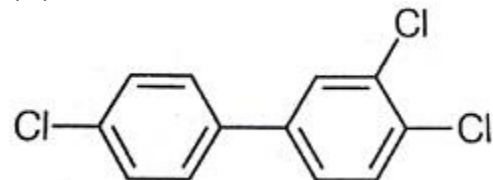

(D)

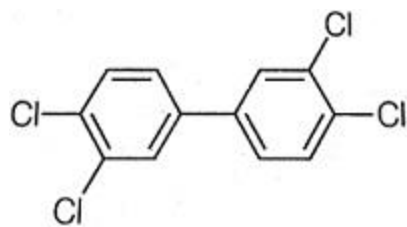

(E)

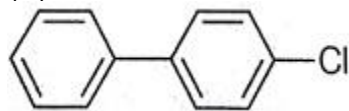

Solution: (B)

2 moles of  $Cl_2$  gives 2 moles of  $Cl^+$  ions, which are attached at *p*-position of both the rings.

Hence, final product will be

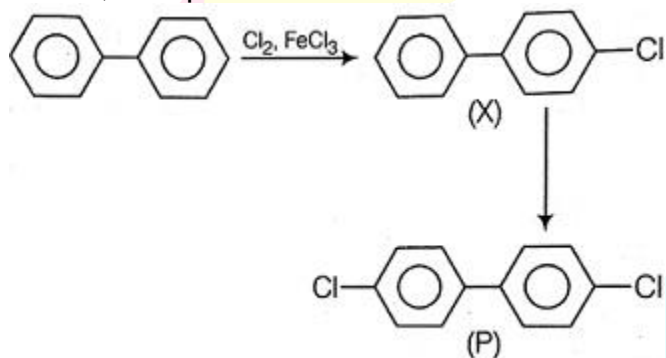

Here,  $FeCl_3$  act as a Lewis acid.

42. The correct increasing order of the acidic strength of acids, butyric acid (I), 2-chlorobutyric acid (II), 3-chlorobutyric acid (III) and 2, 2-dichlorobutyric acid (IV) is

- (A)  $I < II < III < IV$   
 (B)  $III < II < IV < I$   
 (C)  $I < III < II < IV$   
 (D)  $III < I < II < IV$   
 (E)  $IV < III < II < I$

Solution: (C)

Among the acids

- (i) Butyric acid  
 (ii) 2- chlorobutyric acid  
 (iii) 3- chlorobutyric acid  
 (iv) 2- dichlorobutyric acid

The acidic strength increases on

- (i) Presence of electron withdrawing group (i.e.  $-I$  group)  
 (ii) Closeness of electron withdrawing group from the  $-COOH$  groups  
 (iii) Number of electron withdrawing groups (i.e.  $-I$  group)

Hence, the correct order will be

$I < III < II < IV$

43. Cycloheptatrienyl cation is  
 (A) Non-benzenoid and non-aromatic  
 (B) Non-benzenoid and aromatic  
 (C) Benzenoid and non-aromatic  
 (D) Benzenoid and aromatic  
 (E) Non-benzenoid and anti-aromatic

Solution: (B)

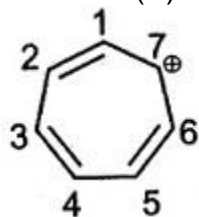

Cycloheptatrienyl cation has 7-carbon atoms in a ring with  $6\pi$  electrons and a planar structure. Thus, it is a non-benzenoid aromatic species.

44. The correct order of increasing reactivity of the following alkyl halides,

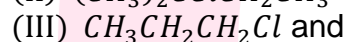
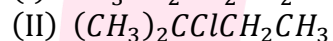
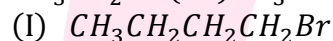

(IV) Towards  $S_N2$  displacement is

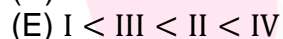
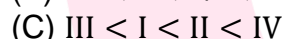
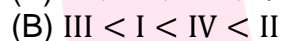
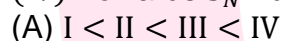

Solution: (B)

The reactivity of alkyl-halides towards  $S_N2$  depends on

(i) Degree of C-atoms

Reactivity order  $1^\circ > 2^\circ > 3^\circ$

(ii) Electronegativity of halogen

Reactivity order  $I > Br > Cl > F$

Hence, correct order is

III < I < IV < II

45. The strongest base among the following is

(A) Amide ion

(B) Hydroxide ion

(C) Trimethylamine

(D) Ammonia

(E) Aniline

Solution: (A)

Least stable be the species ion, more basic be the given species.

As  $NH_2^-$  (amide ion) is the least stable species ion. Thus, it is the most basic species.

Hence, (Amide ion) is the correct answer.

46. The condensation reaction between one equivalent of acetone and two equivalents of benzaldehyde in presence of dilute alkali leads to the formation of

- (A) Benzalacetophenone
- (B) Benzylideneacetone
- (C) Dibenzylideneacetone
- (D) Benzoic acid and acetic acid
- (E) Only benzoic acid

Solution: (C)

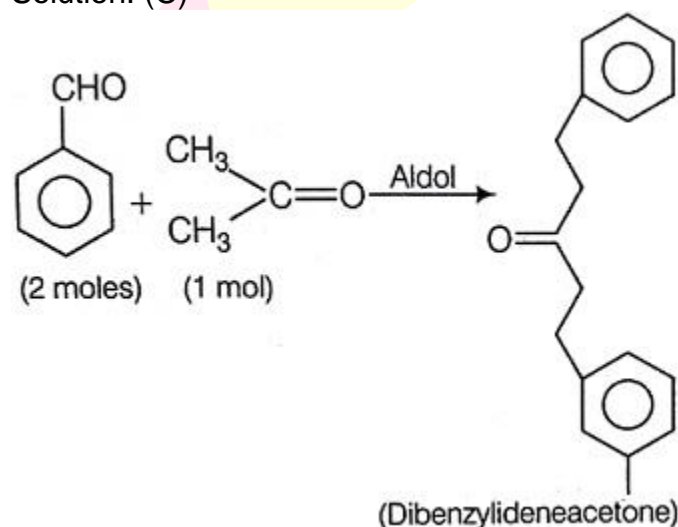

When two moles of benzaldehyde react with one mole of acetone. It shows aldol condensation as follows:

Hence, (Dibenzylideneacetone) is the correct answer.

47. The product Y for the below reaction is

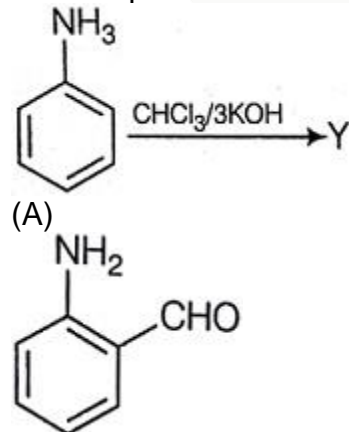

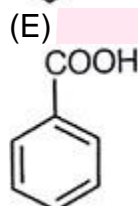
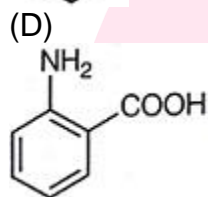
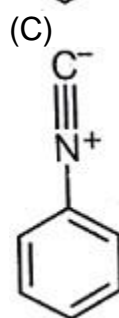
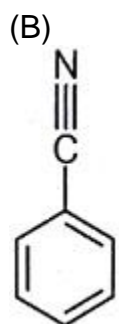

Solution: (C)

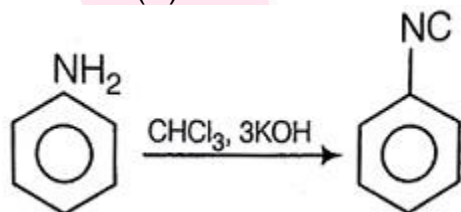

This is a carbalamine reaction. It gives isocyanide as main product.

48. The product formed in the following reaction is

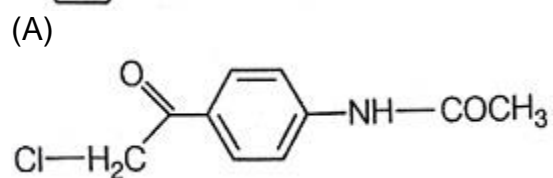
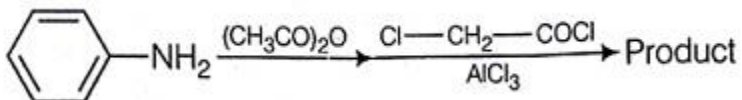

(B)

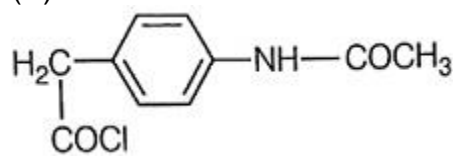

(C)

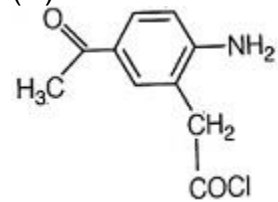

(D)

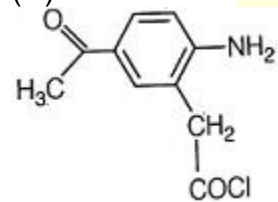

(E)

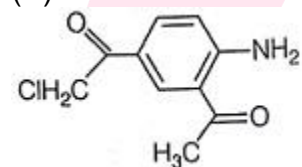

Solution: (A)

